

Variable swirl diffusers

■ Variable swirl diffuser OD-11

Application

Diffuser is designed for air conditioning of rooms with floor to ceiling highs of 3 to 10 m and high induction requirements. It is suitable for large temperature difference between supply and room air.

Description

Diffuser is made of housing which has a diffusing funnel mounted at the bottom. The direction of the discharged air is altered via the separately adjustable blades. The shape of the diffuser's inner part allows "Coanda" effect.

Housing consists of sheet aluminium and blades of pickled sheet steel. Complete diffuser is powder painted in RAL 9010 or any colour upon customer's request.

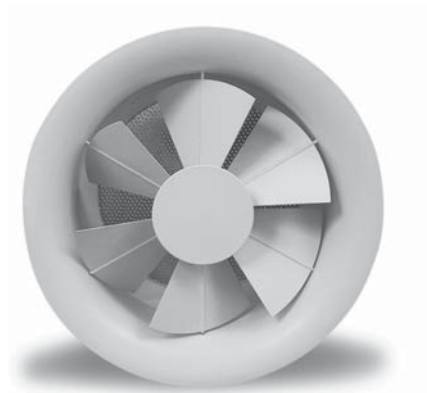

Individually adjustable blades OD-11

Use of the individually adjustable blades is recommended when the ventilation system is designed for the specific mode of operation and the blades can be adjusted during the diffuser installation.

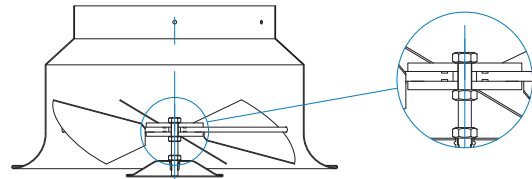

Variable swirl diffuser OD-11V

Version OD-11V has centrally adjustable blades. Blades can be manually adjustable or by the means of electric motor installed on the outer side of the diffuser or by thermostat regulation. Diffuser is capable of altering discharge direction.

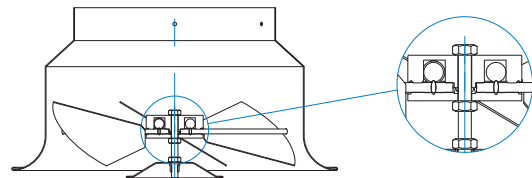

Variable swirl diffuser with the thermostat regulation OD-11V/TR

OD-11V/TR diffuser has a basic implementation of OD-11V upgraded thermostatically controlled. Automatic continuous regulation operates as a function of the temperature of air flowing through the diffuser. With additional configuration before installation to ensure optimum operation of the demands of comfort in the room.

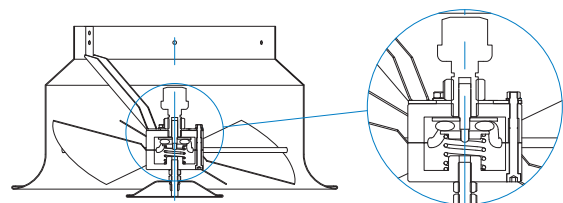

Regulation with the OD-11V/.../RR handle

Regulation with this handle enables manual blade angle adjustment if the diffuser placement allows access to the handle. This type of regulation is suitable for buildings with a lower number of diffusers when the ventilation system is designed for both summer and winter operation.

1. handle
2. fixing screw

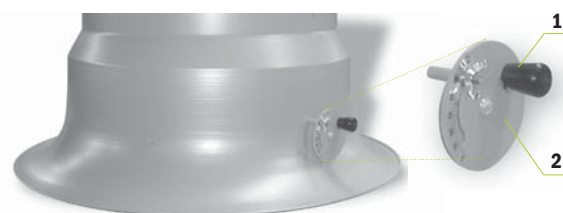

■ OD-11V with the ADT-2 thermostat with analogue output

Description

The ADT-2 differential thermostat with continuous analogue output is a controller that, based on the duct air temperature and room temperature signals, automatically adjusts the angle of OD-11V blades as required.

One ADT-2 can operate up to 10 OD-11V units.

Operation

The controller compares the selected temperature curve, which is set according to the OD-11V position, desired mode of operation, etc. with data received from temperature sensors located in the air supply duct and in the room. Taking into account the desired temperature difference, the controller generates a continuous analogue 0-10V DC output signal, which is then transmitted to the OD-11V electric motor drive. Comparing the temperature, the controller automatically recognises the heating or cooling mode and sets the OD-11V accordingly. In the case the duct air temperature is higher than the room temperature, the controller switches the OD-11V to the heating mode, i.e. to the vertical supply of warm air into the room. In the case the duct air temperature is lower than the room temperature, the controller automatically infers that the system is in the room cooling mode and accordingly generates a signal to set the OD-11V to the cooling mode.

Advantage

Applying ADT-2, the need for manual switching of a large number of OD-11V units to the proper operational mode is avoided, since the controller switches the units automatically. In this way, the efficiency of room air conditioning is enhanced as well.

ADT-2 differential thermostat

1. controller
2. room temperature sensor
3. duct temperature sensor
4. compact actuator (B3, B6, B9)

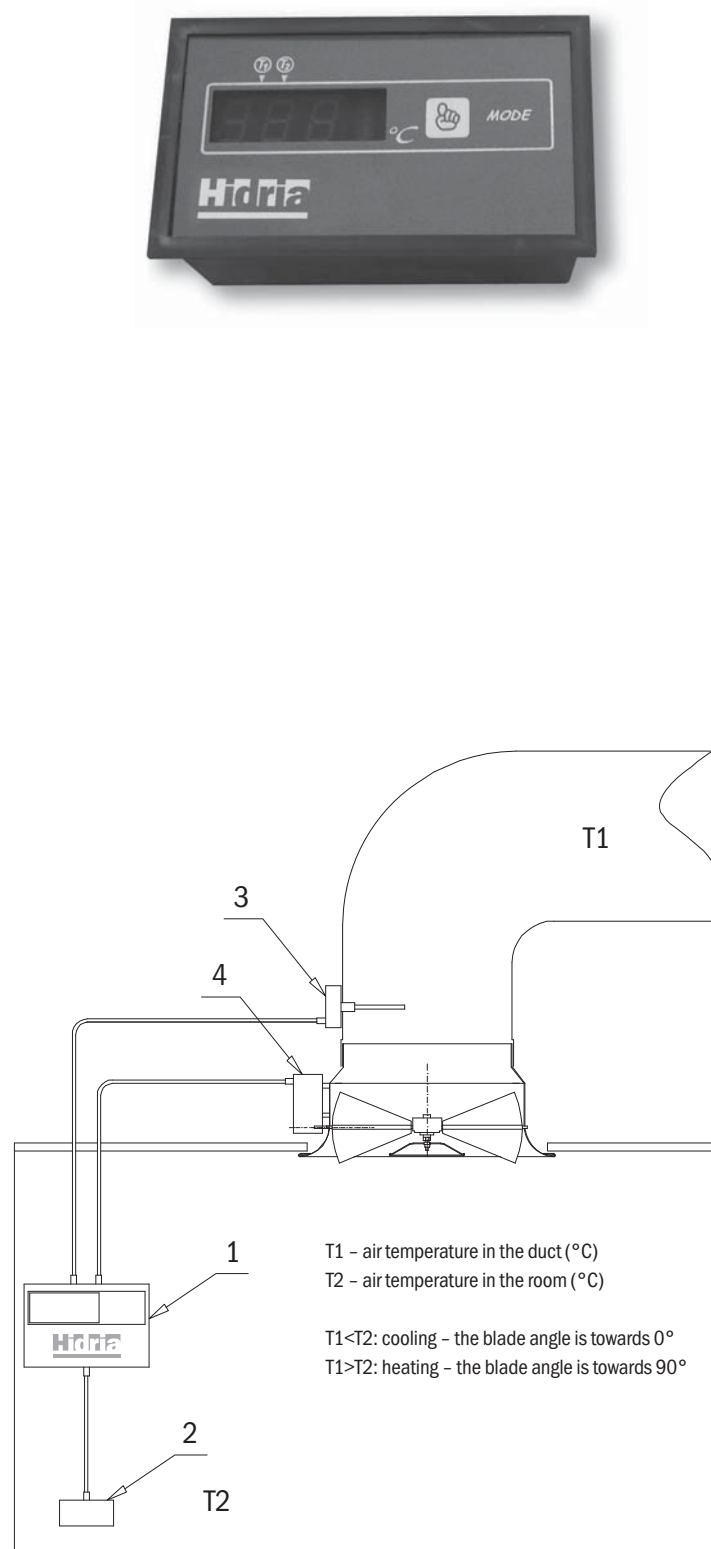

Variable diffuser with the thermostat regulation OD-11V/TR

Operation

At OD-11V/TR diffuser, centrally adjustable blades can be adjusted automatically with the thermostat regulation. Thermostat perceives temperature of the supply air and automatically adjusts the blades angle. No additional power supply and controls are required, so no additional wiring installation is needed. Blade angle according to the supply air temperature is shown in the chart below.

A hysteresis behavior of the thermostatic head in both cooling and heating mode is shown in the chart. After the temperature is stabilized, angle of the blades is adjusted to the medium value in about 15 minutes.

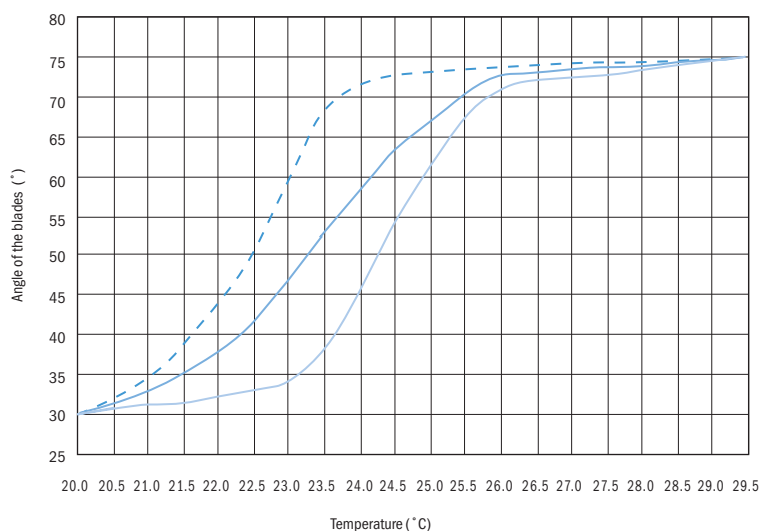

Size

OD-11V/TR diffuser can be made in sizes 200, 250, 315, 400, 500, 630 and 800 (sizes 125 and 160 are not available).

Regulation of the initial and final blade angle

OD-11V/TR allows the regulation of the initial and final blade angle.

During the selection of appropriate diffuser for certain room conditions with the Klima ADE software package, exact angles are calculated according to the installation height of the diffuser, supplied air quantity and the temperature difference between supplied and room temperature. Calculation is based on air flow speed of 0.2 m/s in the living area.

Initial blade angle is preadjusted with the special nut in the range between 30 and 50°. Automatic opening of the blades is initiated, when the temperature reaches limit value, shown in the chart according to the preadjusted angle and number of used spacers. When initial angle of 45° is preadjusted without additional spacers and final angle is 75°, blade opening temperature is between 22.5 and 23 °C (designation 1 in diagram).

Final blade angle is adjusted by adding spacers below thermostatic head. Default preassembled spacer allow complete opening of the blades until 75°. By each added spacer, final angle is reduced for 5°.

Adding of spacers also change the thermostatic head characteristics (average values according to the number of added spacers are shown in the chart).

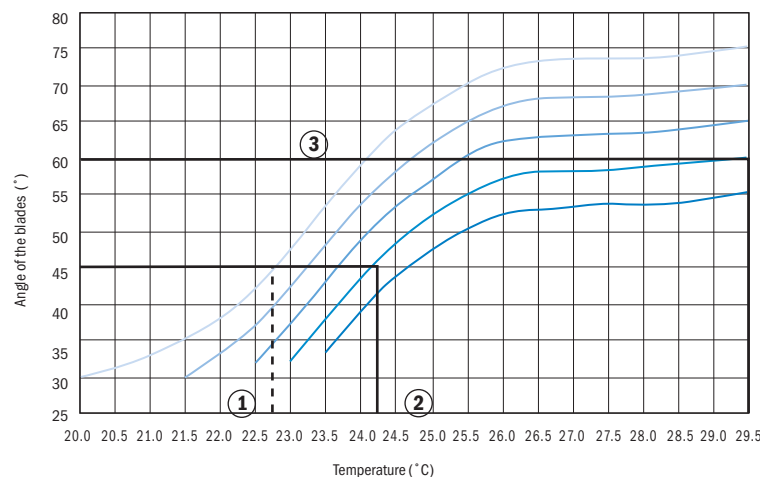

Nr. of spacers added	0	1	2	3	4
Final blade angle	75°	70°	65°	60°	55°

Calculation example of initial and final blade angle for the OD-11V/TR diffuser with the Klima ADE 5.4 software package

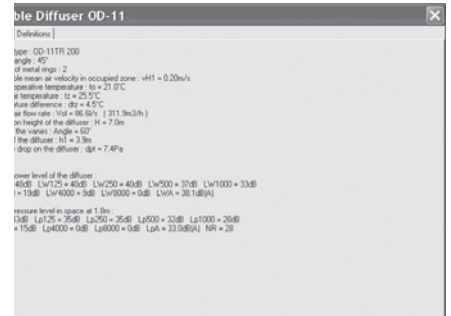
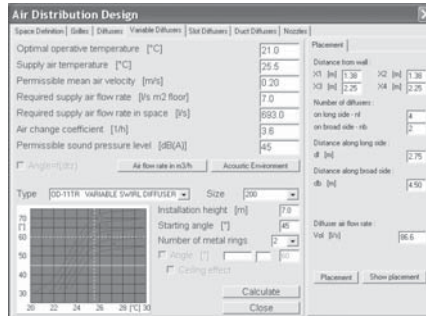
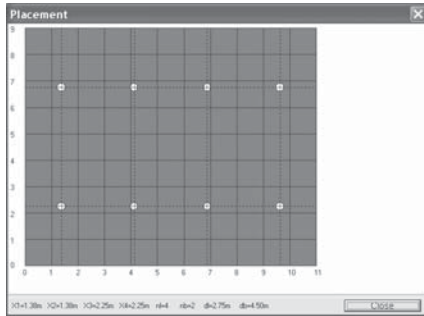

Input data:
Air quantity
Air temperature
Room size
Diffuser size

Calculation

Result of the calculation:
minimum angle in
the cooling mode = 45°

Angle adjustment (designation 2 in diagram):

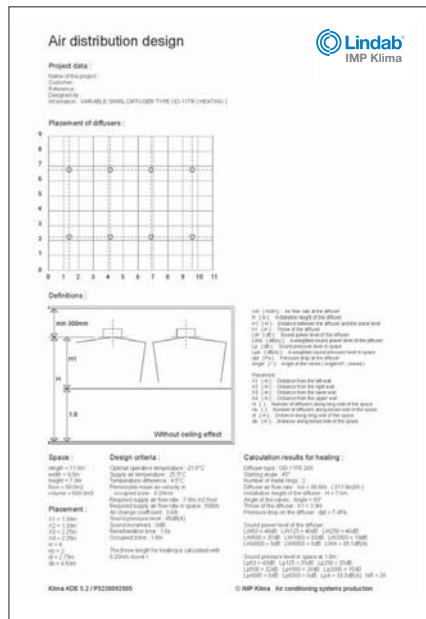
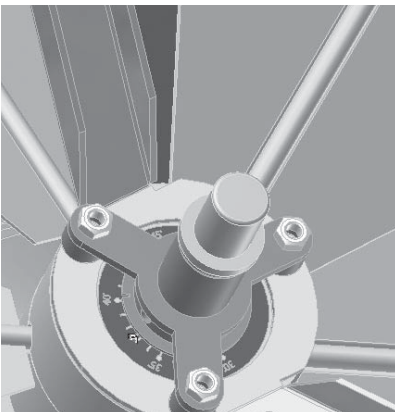

Result of the calculation:
maximum angle in
the heating mode = 60°

Angle adjustment (designation 3 in diagram):

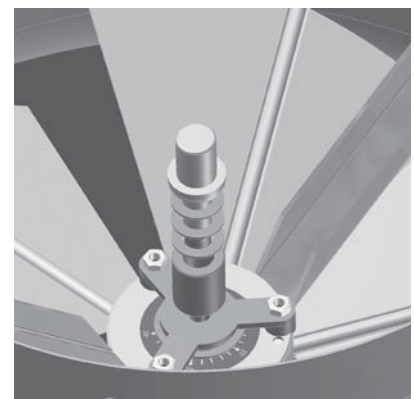

for 60° three spacers should be used

Summer: cooling

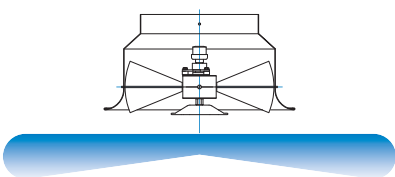

Transitional period: automatic adjustment of blade angle to the supply air temperature

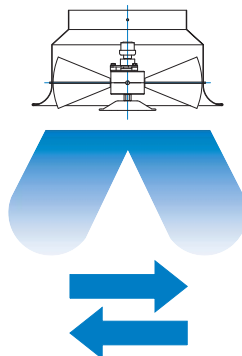

Winter: heating

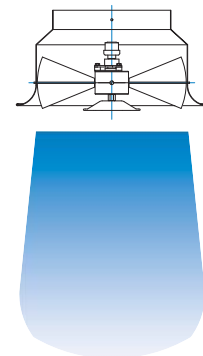

Dimensions

Size	ΦD	ΦD2	C	C1	A _{ef} (m ²)
125	125	205	130	40	0.012
160	160	250	155	40	0.020
200	200	310	174	40	0.030
250	250	400	200	40	0.048
315	315	480	240	40	0.077
400	400	615	265	55	0.125
500	500	790	320	60	0.195
630	630	940	380	80	0.310
800	800	1142	555	75	0.503

A_{ef} - effective discharge area (m²)

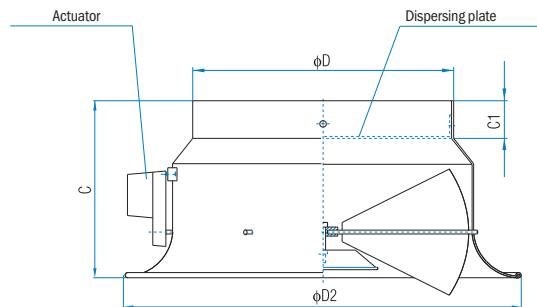

Installation of diffuser on a plenum box

1. Plenum box
2. Inlet spigot
3. Dispersing plate
4. Volume control damper M
5. Traverse
6. Diffuser OD-11, OD-11V, OD-11V/TR
7. Adapter

Size	A	H1	h1	Φd	ΦD	ΦA1
125	230	185	112	98	128	205
160	280	210	125	123	163	250
200	325	240	137	158	204	310
250	390	290	167	198	254	400
315	590	325	177	248	319	480
400	590	390	210	313	404	615
500	590	390	210	313	504	790
630	655	530	280	448	634	940
800	1049	630	340	498	804	1142

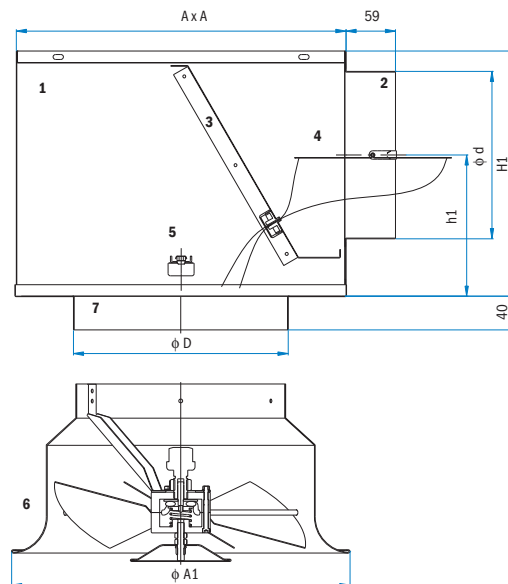

Round plenum box

1. Plenum box
2. Inlet spigot
3. Suspension bracket
4. Volume control damper M
5. Dispersing plate
6. Diffuser OD-11, OD-11V, OD-11V/TR

Size	ΦD	H	H1	Φd
125	128	250	154	98
160	183	250	166	123
200	204	245	144	158
250	254	285	164	158
315	319	335	189	248
400	404	400	221	313
500	504	400	221	313
630	634	535	289	448
800	804	585	314	498

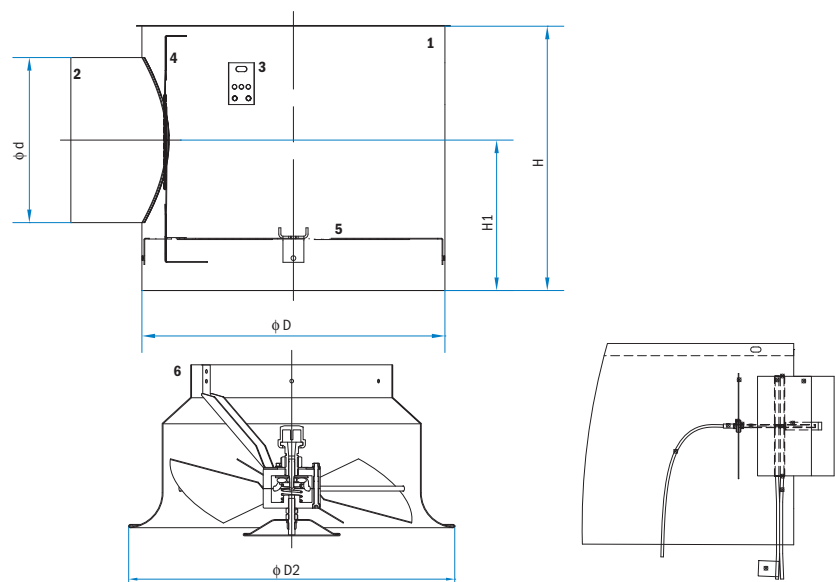

Ordering key

OD-11 / P / Z / M / I Size 200

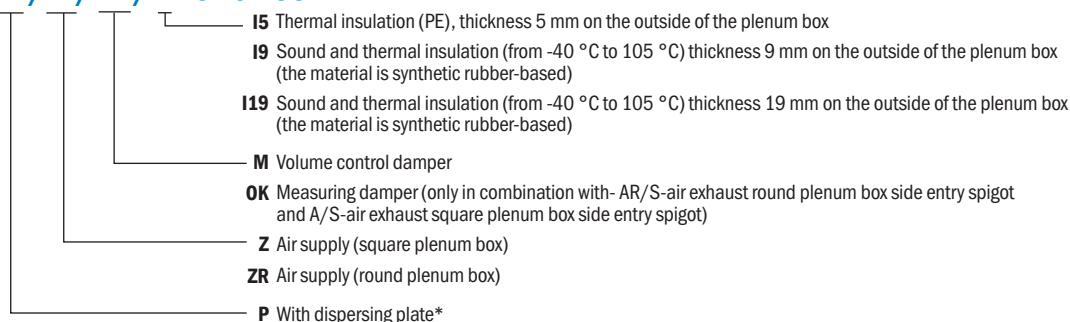

*Dispenser plate is not installed if the chamber is used for installation.

Ordering key

OD-11 V / P / B1 / Z / M / I Size 200

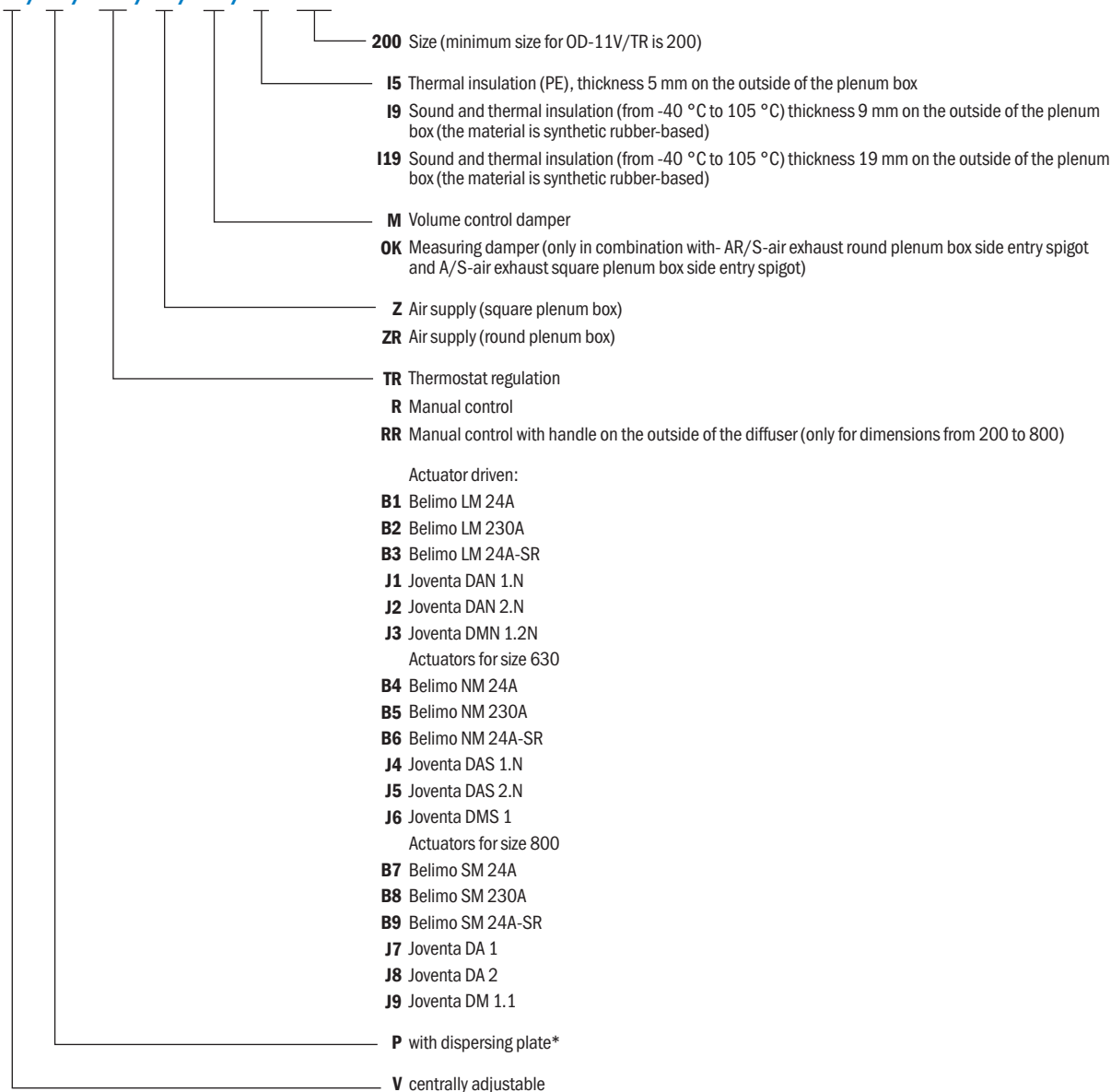

*Dispenser plate is not installed if the chamber is used for installation.

Definition of symbols

Q (m ³ /h)	Air flow
x (m)	Horizontal distance to the wall
H (m)	Room height
H_1 (m)	Distance from ceiling to occupied zone
L (m)	Throw distance ($L=H+1+x$)
V_L (m/s)	Air velocity at the throw distance L
Δt_z (K)	Temperate difference between the supply and room air
Δt_r (K)	Difference between the core and room air temperature
Δp_r (Pa)	Pressure drop
L_{WA} (dB(A))	Sound power level
V_{H1} (m/s)	Air velocity at the H_1 distance
A, B (m)	Distance between diffusers by length and by width

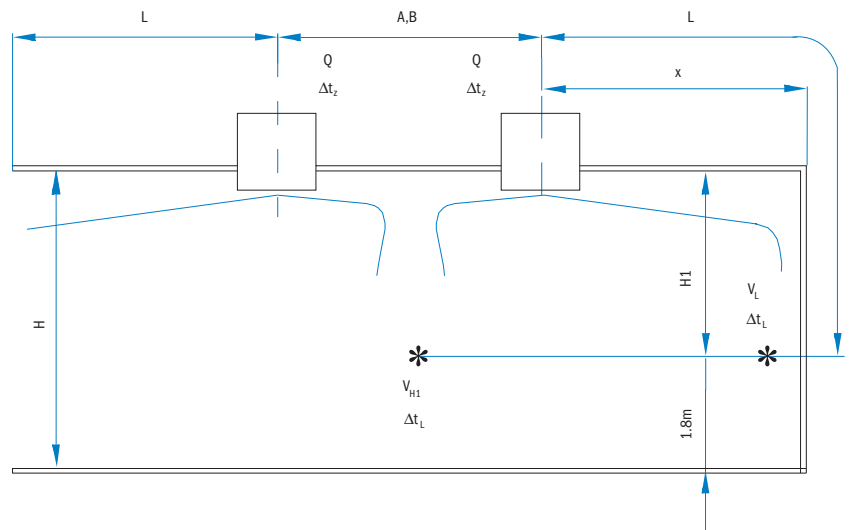
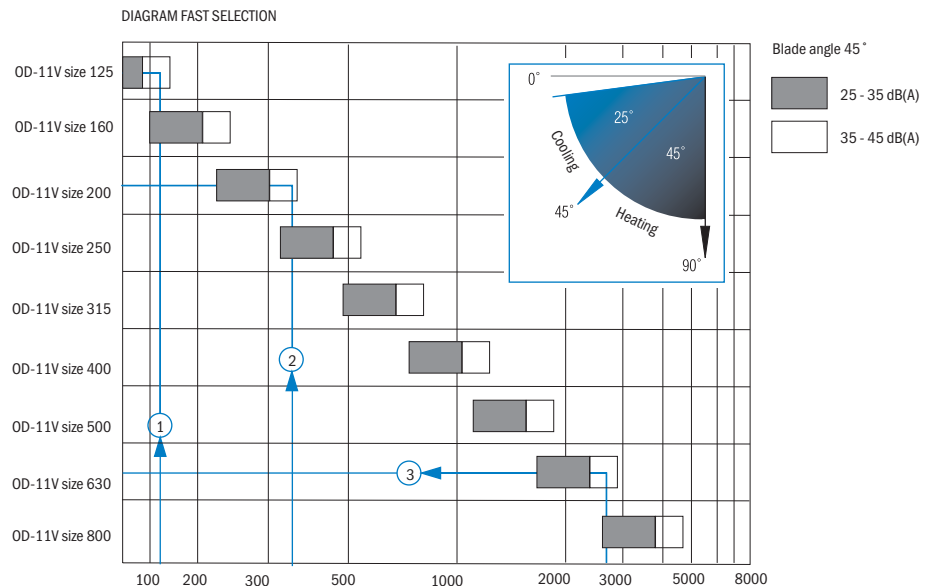

Diagram for fast selection

Corections

In the case of the diffuser installation in the ceiling, the velocity V_h at the level $A/2+H$ is to be multiplied with a factor of 1.4 (due to the Coanda effect).

The above applies to the cases of heating and cooling operation with blade opening angles less than 30°.



Examples for selection 1, 2 and 3: see the following pages.

Diffuser size as a function of distance between units and effective velocity

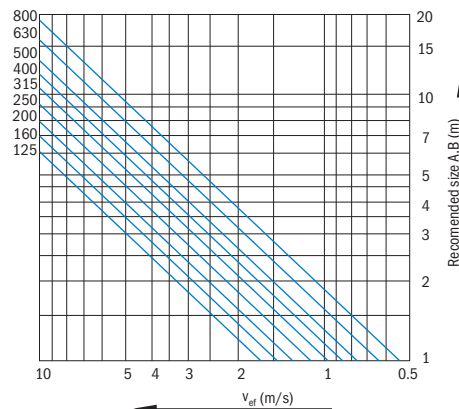

Blade opening angle during heating and cooling operation

Calculation

Example 1 (cooling)

$Q = 160 \text{ m}^3/\text{h}$
 $H = 3 \text{ m}$
 $H1 = H - 1.8 = 3 - 1.8 = 1.2 \text{ m}$
 $v_{H1} = 0.2 \text{ m/s}$
 $\Delta T_z = -5 \text{ K}$
 Recommended size: 125
 $v_{ef} = Q / (A_{ef} \times 3600) = 160 / (0,012 \times 3600)$
 $v_{ef} = 3.6 \text{ m/s}$
 $v_{H1} / v_{ef} = 0.2 / 3.6 = 0,056$
 Blade angle: 41°

Example 1 (heating)

$Q = 160 \text{ m}^3/\text{h}$
 $H = 3 \text{ m} \rightarrow H1 = 1,2 \text{ m}$
 $v_{H1} = 0.2 \text{ m/s}$
 $\Delta T_z = 10 \text{ K}$
 Recommended size: 125
 $v_{ef} = 2.7 \text{ m/s}$
 Blade angle: 66°

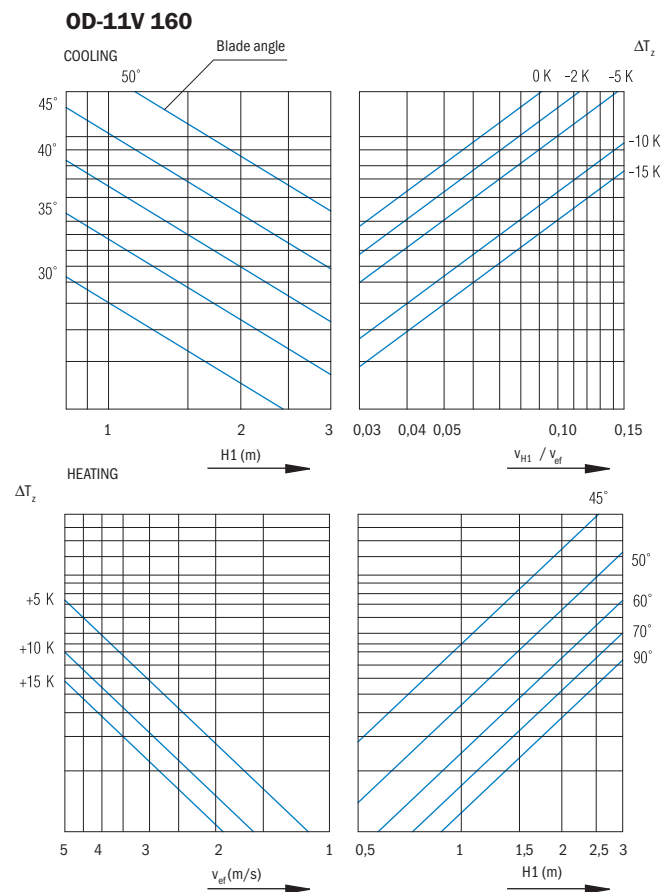
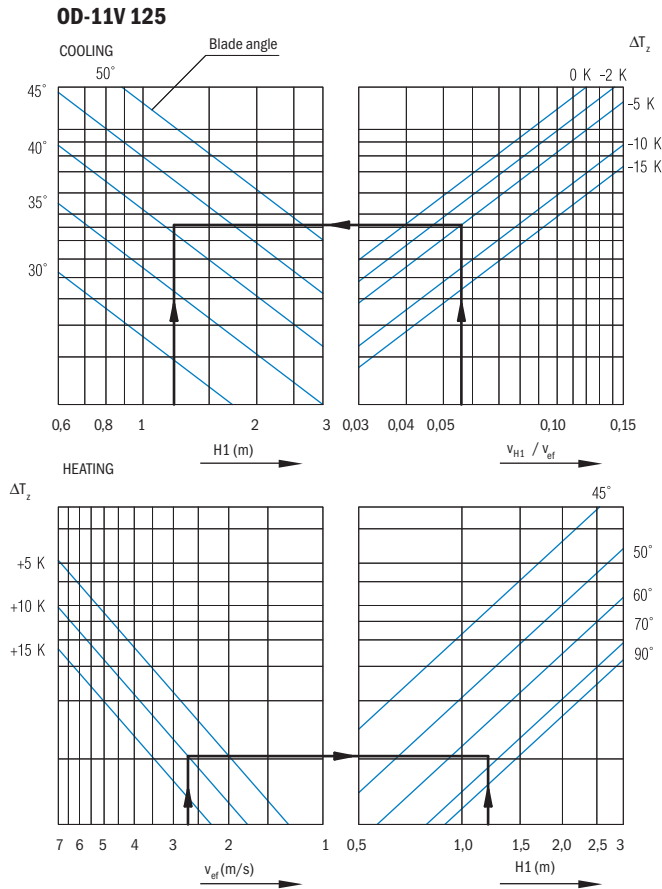

Blade opening angle during heating and cooling operation

Calculation

Example 2 (cooling)

$Q = 350 \text{ m}^3/\text{h}$
 $H1 = 1.4 \text{ m}$
 $v_{H1} = 0.15 \text{ m/s}$
 $\Delta T_z = -10 \text{ K}$
 Recommended size: 200

$v_{ef} = Q / (A_{ef} \times 3600) = 350 / (0,031 \times 3600)$
 $v_{ef} = 3.13 \text{ m/s}$
 $v_{H1} / v_{ef} = 0.15 / 3.24 = 0.046$
 Blade angle: 32°

((Blade angle $32^\circ \rightarrow$ Coanda effect)
 $H1 = 1.4 \times 1.4 = 1,96 \text{ m}$
 $H = H1 + 1.8 = 1.96 + 1.8 = 3.67 \text{ m}$
 or
 $H = 1.4 \rightarrow v_{H1} = 0.15 \times 1.4 = 0.25 \text{ m/s}$

OD-11V 200

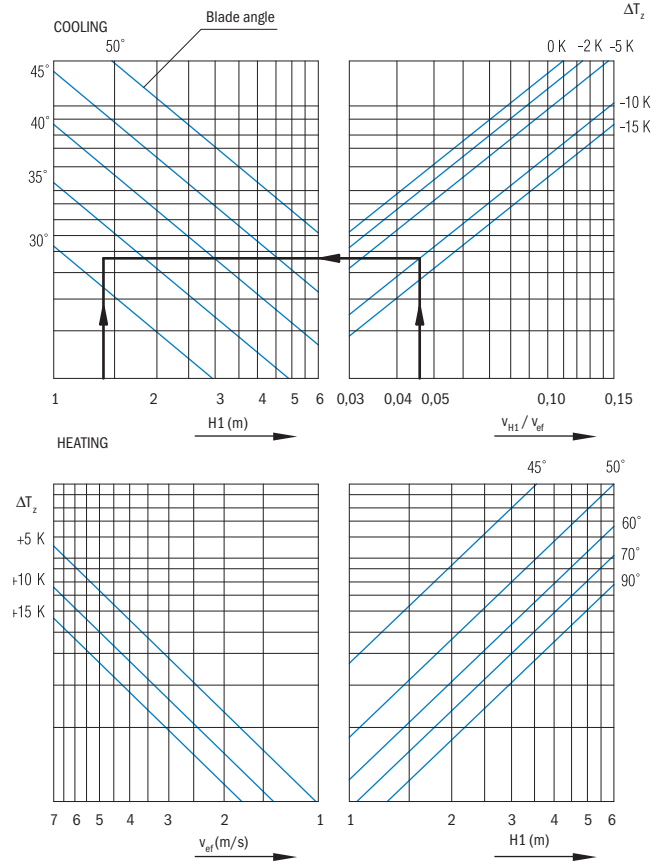

OD-11V 250

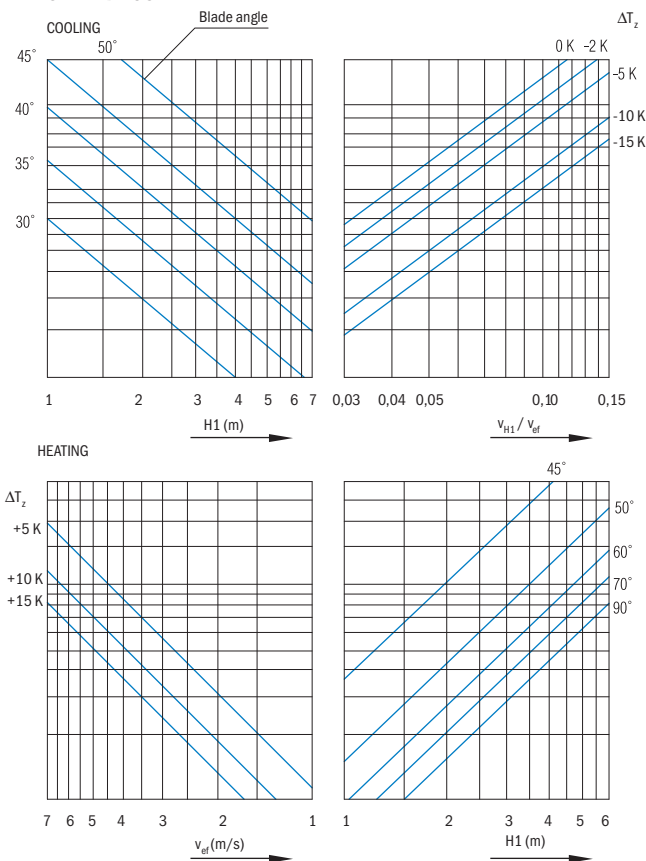

OD-11V 315

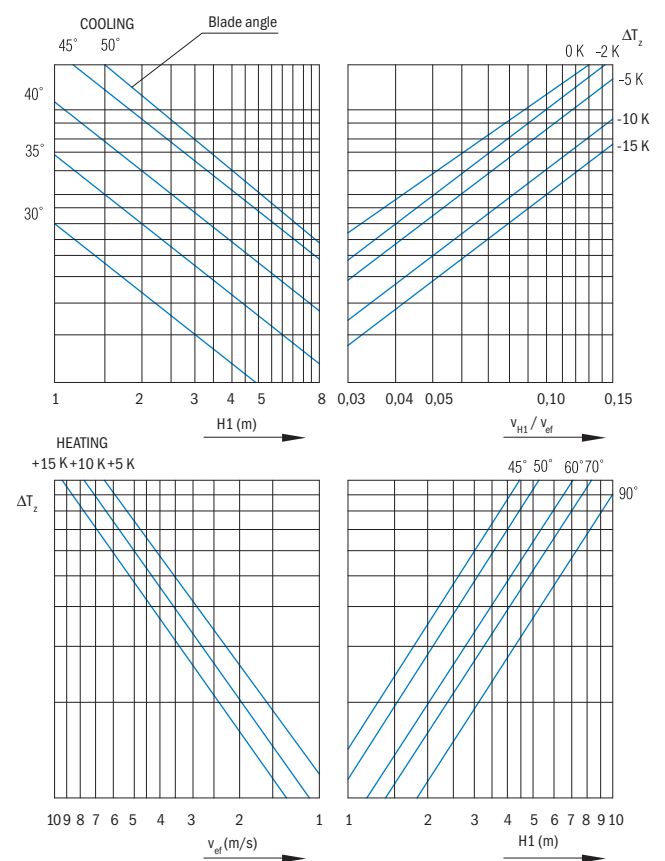

Blade opening angle during heating and cooling operation

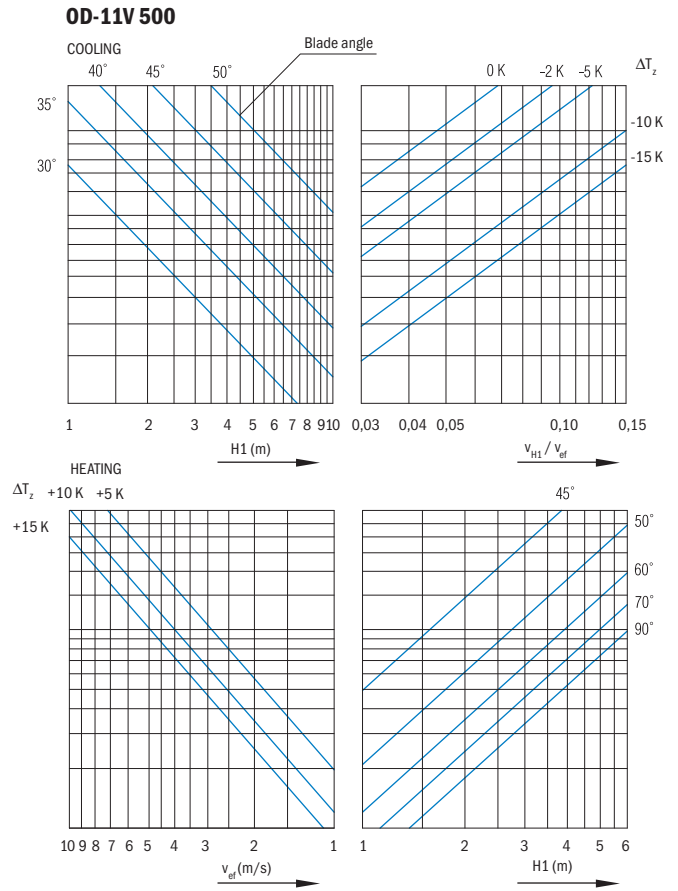
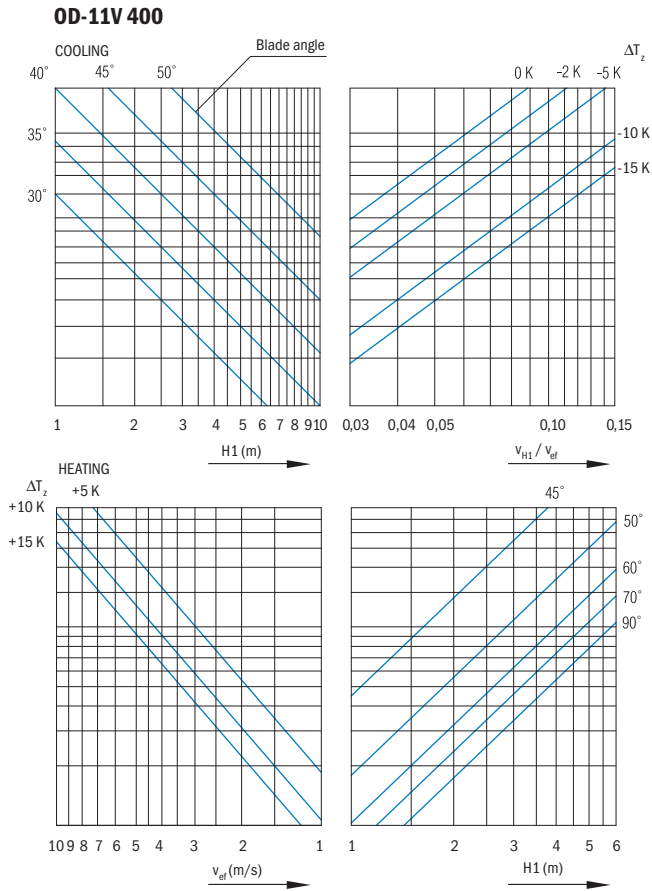

Calculation

Example 3 (cooling)
 $Q = 2700 \text{ m}^3/\text{h}$
 $v_{H1} = 0.2 \text{ m/s}$
 $\Delta t_z = -10 \text{ K}$
 $H = 9 \text{ m} \rightarrow H1 = 9 - 1.8 = 7.2 \text{ m}$
 Recommended size: 630

$v_{ef} = Q / (A_{ef} \times 3600) = 2700 / (0.32 \times 3600)$
 $v_{ef} = 2.3 \text{ m/s}$
 $v_{H1} / v_{ef} = 0.2 / 2.3 = 0,08$
 Blade angle: 44°

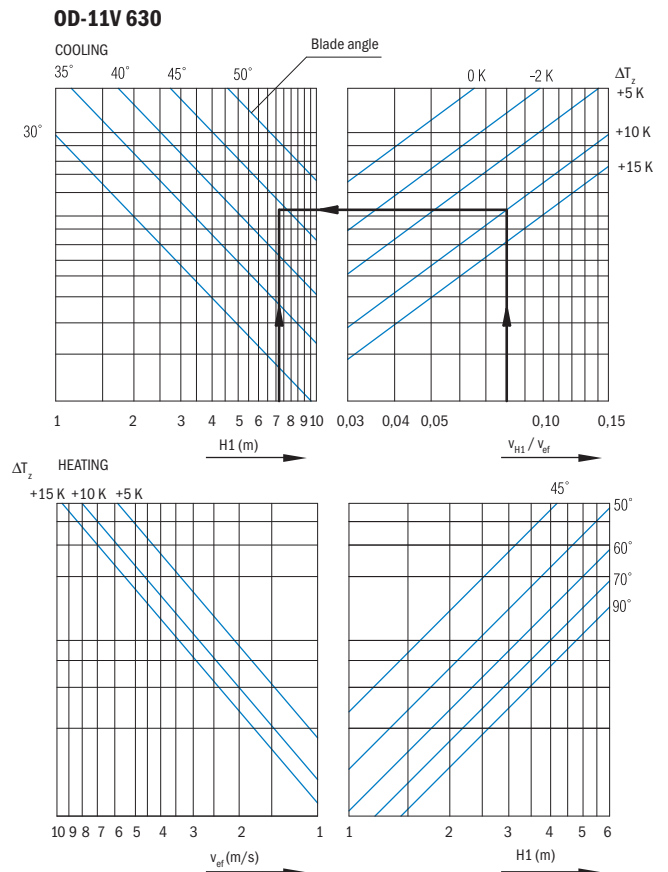

VENTILATING GRILLES,
VENTILATING VALVES

CIRCULAR DIFFUSERS,
SQUARE DIFFUSERS

SWIRL DIFFUSERS,
VARIABLE SWIRL
DIFFUSERS

SLOT DIFFUSERS,
ROUND DUCT DIFFUSERS

AIR DISPLACEMENT
UNITS

SUPPLY AIR NOZZLES

EXTERNAL ELEMENTS

AIR FLOW
CONTROL UNITS

SOUND ATTENUATORS,
SOUND ATTENUATING
LOUVRES

Blade opening angle during heating and cooling operation

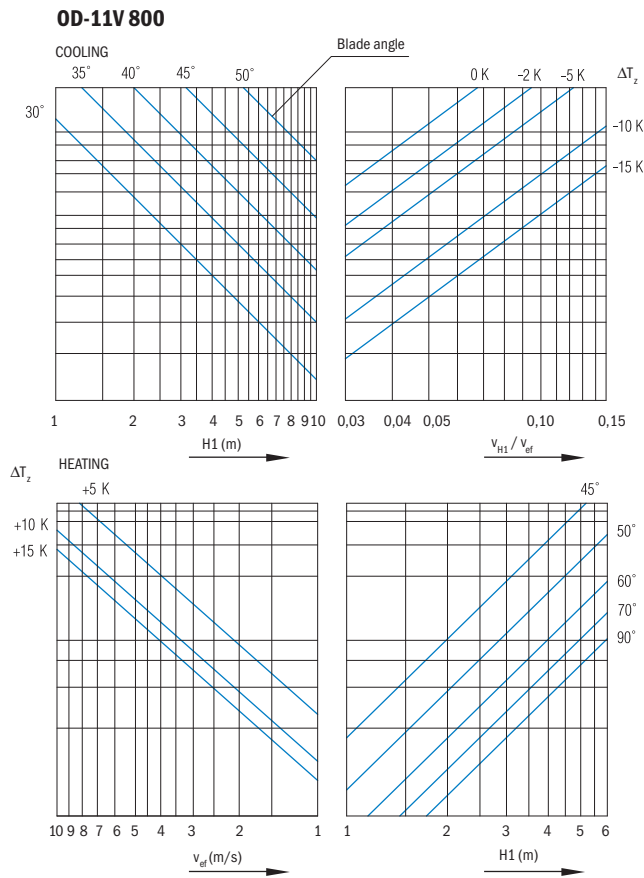

Pressure drops and sound power level

(for version with dispersing plate)

OD-11V Size 125 - 800

PRESSURE DROPS AND SOUND POWER LEVEL

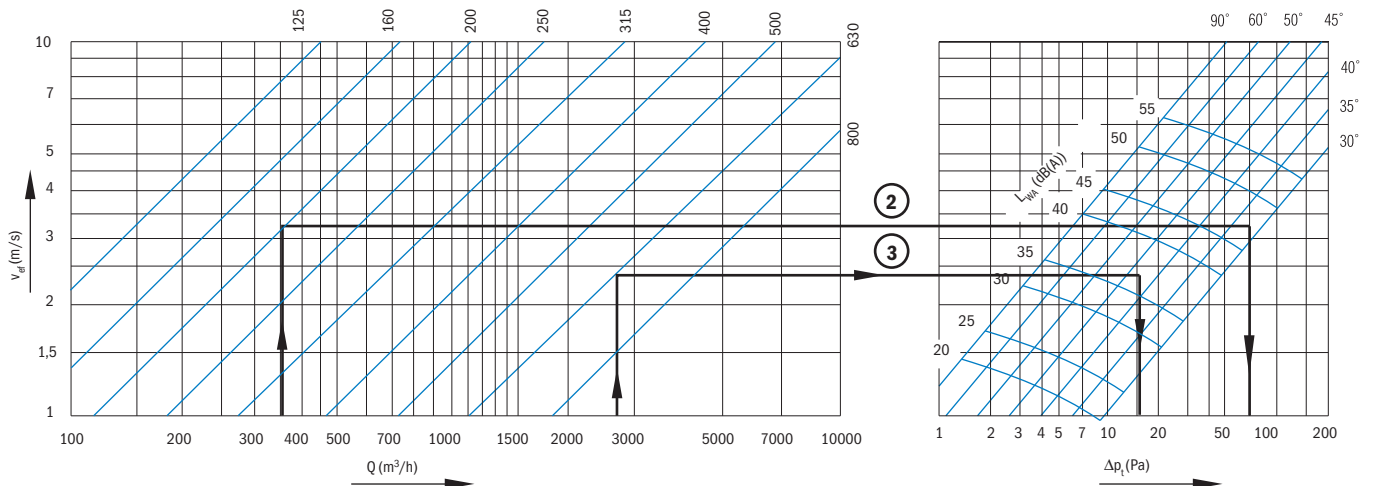

Calculation

Example 2 (cooling)

$Q = 350 \text{ m}^3/\text{h}$

$L_{WA} = 47 \text{ dB(A)}$

$\Delta p = 75 \text{ Pa}$

Blade angle: 32°

Example 3 (cooling)

$Q = 2700 \text{ m}^3/\text{h}$

$L_{WA} = 37 \text{ dB(A)}$

$\Delta p = 16 \text{ Pa}$

Blade angle: 44°