

Technical Brochure

LTG Air Distribution

Variable Flow Rate Controllers
VRDactive

active
control

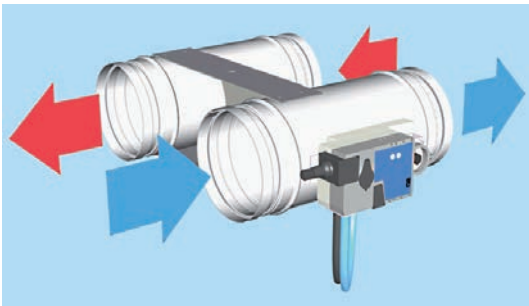

Round, with LTG Map Control

Technical brochure • Variable Flow Rate Controllers VRDactive

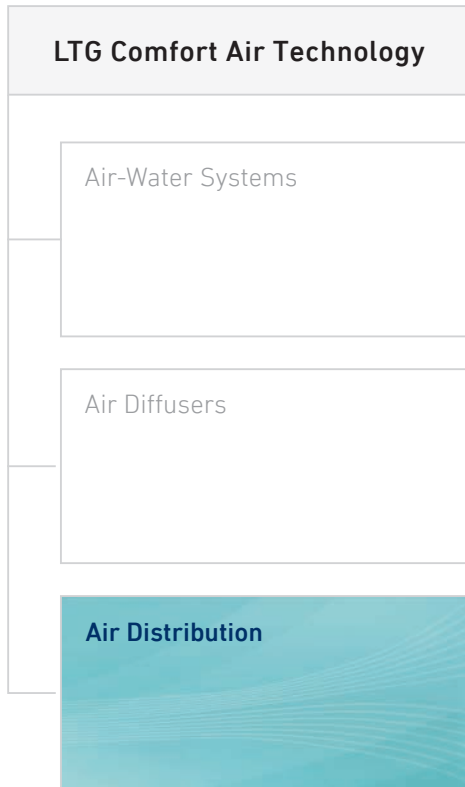

Content	Page
Description	4
Characteristics, materials/finishes, accessories/ special versions, connection, recommendations for selection, flow rate range	5
Application ranges/limits, control accuracy, straight inflow distances	6
Dimensions, weights	7
Airborne sound transmission	8
Casing sound transmission	10
Calculation exemples	12
Nomenclature, ordering code	14

Notes

Dimensions stated in this brochure are in mm.

Dimensions stated in this brochure are subject to General Tolerances according to DIN ISO 2768-vL.

Possible additional details are stated in the drawings.

Straightness and twist tolerances according to DIN EN 12020-2.

The actual specifications are available as a word document at your local distributor or at www.LTG.net.

LTG planning tools – we support you!

Visit the download area on our website www.LTG.net with helpful tools, such as dimensioning programs, streaming videos and product information!

Also available: Our product overviews about air diffusers, air-water systems, decentralized ventilation units and air distribution products.

DOWNLOADS

ProductNavigator & DocumentFinder



ProductNavigator
Please choose your desired product.



DocumentFinder
Please choose your desired type of documents.

Technical brochure • Variable Flow Rate Controllers VRDactive

Flow Rate Control Basics – Which Product for which Application?

Plant Types

Variable Flow Rate

Plants with variable flow rates (VVS) use electronic flow rate controllers providing the room with exactly the required air volume – according to function and energy efficiency.

Constant Flow Rate

Plants with constant flow rates (KVS) use flow rate controllers maintaining a constant flow rate mechanically system-powered. Working with no wiring or external power supply, they provide convenient and cost-saving solutions.

Measuring Methods

Dynamic Differential Pressure Management

Dynamic methods measure part of the air that is guided through the differential pressure transducer. Dynamic differential pressure measuring makes economical sense in plants where no dust and/or chemical pollution of the air is expected, potentially leading to the contamination of sensors (e. g. administration and office buildings, museums, etc.).

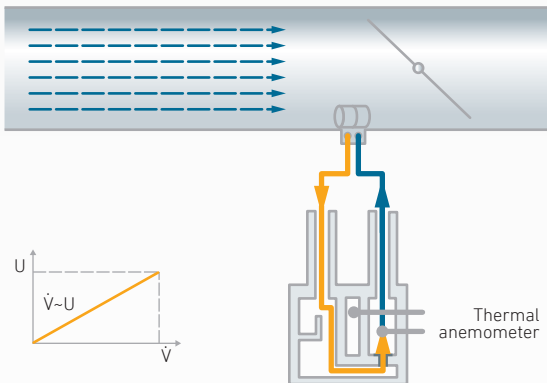

Static Differential Pressure Management

Static differential pressure measurement uses a diaphragm pressure transducer. With this method, no air is guided through the sensor, so no dust or chemical pollution by the air is possible and hence, may well be used in such environments..

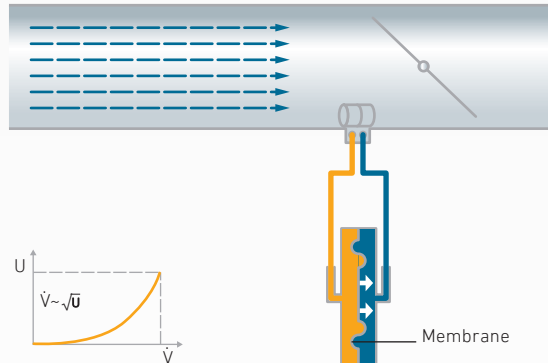

Both principles are applied in our products of VR... series: VR*active* (dynamic) und VR*active-s* (static).

LTG Map Control

Differential pressure + Damper setting = Flow rate

Contrary to common measuring techniques, the differential pressure is not measured using an upstream element such as orifice plate or differential pressure sensor. Flow rate controllers VR*active* measure the differential pressure directly in the damper blade area (stronger signal due to locally accelerated air flow).

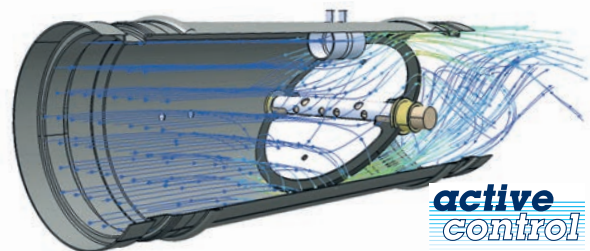

Locally accelerated air flow at the measuring point

Technical brochure • Variable Flow Rate Controllers VRDactive

View of unit



Application

The compact flow rate controller unit VRDactive works with auxiliary power and controls a constant or variable flow rate independent of the initial pressure in two parallel air ducts as follows: The flow rate is measured and controlled based on set values, either on the air inlet side (air inlet side controlled ventilation) or on the air outlet side (air outlet side controlled ventilation). The other non-measured air flow is controlled synchronously because of the rigid mechanical connection between the two dampers. This also ensures safe and complete shut-off.

To ensure steady indoor air pressure conditions in all controlled areas of one duct run it is recommended with air inlet side controlled ventilation to measure the inlet air flow in its entirety (e.g. MSE (round) or MSF (rectangular)) and to track the return air of the duct run by use of a flow rate controller. Cutting back the number of flow rate controllers may result in considerable savings with respect to investment and data points.

Depending on the model size and flow rate, the minimum initial pressure difference is approx. 5 Pa...approx. 50 Pa, based on duct air speeds of 1...10 m/s.

The casing is provided with plug-in ends to suit air ducts acc. to DIN EN 1506. All components are factory-wired and hose-connected.

For sound and heat insulation, a 50 mm mineral wool insulating shell with sheet steel jacket is available.

Measuring Principle

Contrary to conventional measuring techniques, the differential pressure is not measured through a upstream element such as an orifice plate or sensor. Instead, the differential pressure is measured by two cup-shaped elements mounted in the damper blade area.

Placing the damper blade in the throttle position creates a "jet effect" in the damper blade area which is concentrated with reduced flow rates and thus higher throttle settings.

This results in increased air speeds at the measuring point even with lower duct air speeds allowing for relatively high and very precisely measurable differential pressures.

With this measuring principle, the highest control accuracy of all known systems is achieved even with very low air speeds.

Using this technique, flow rate control depends on two values, the differential pressure and the damper blade position.

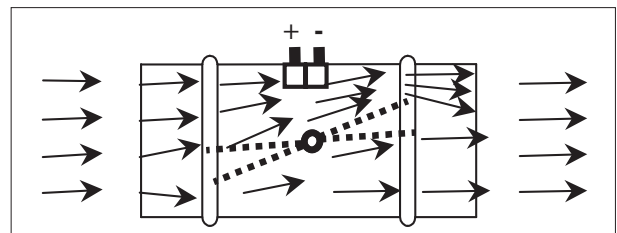

Flow pattern inside the casing

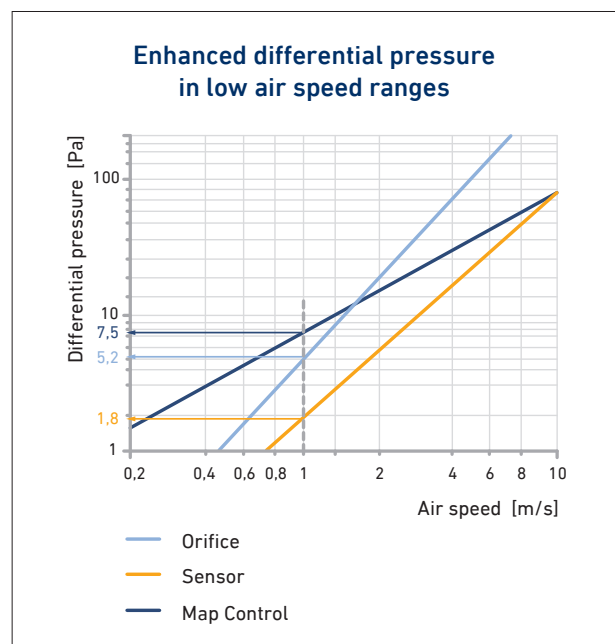

Output comparison of different measuring principles

Technical brochure • Variable Flow Rate Controllers VRDactive

Characteristics

- Cost-saving design and low wiring expenses due to one compact controller being used for both supply and return air.
- Excellent control accuracy from $\pm 5\%$ (V_{nom}) up to $\pm 15\%$ (V_{min}).
- Short installation length thanks to differential pressure measurement in the damper blade area. Thus, perfect for retrofitting and limited-space installation conditions.
- High control ratio of 1:10 (air speeds in the air duct 1...10 m/s).
- Low minimum pressure loss, resulting in energy savings during operation and lower noise generation.
- Very low air leakage rate via the closed damper blade acc. to DIN EN 1751 Class 4 (DN 100 and 125: Class 3).
- Good control accuracy even in case of unfavourable entry conditions, due to "jet effect".
- Plug-in end pieces with lip-seal gasket by default

Materials, finishes

- Casing, damper blade, axle and measuring probes of galvanized steel
- Damper bearings of POM plastic
- Sealing of EPDM

Accessories, special versions

- Insulating case for sound and heat insulation
- Flanges acc. to DIN 24154 R1 at both ends
- Flexible sound absorber SDE-AO made of aluminium
- Rigid sound absorber SDE-SO made of galvanized sheet steel
- Compact controller with static measuring method
- Compact controller compatible with MP-Bus, Modbus or BACnet
- Integrated NFC interface for diagnostic and parametrization via smartphone/app
- Service tool ZTH for diagnostic and parametrization

Additional accessories and special versions on request.

Connection

Notes and circuit diagrams for regulating the flow rate can be found in the operating and maintenance instructions.

Recommendations for selection

- Air speed up to 7 m/s
- Flow rate controller pressure loss up to 500 Pa
- If sound emission via air duct surfaces is critical, all ducts including the flow rate controller must be sound insulated up to the sound absorber.
- For sound absorbers, the flow noise downstream of the splitters and the noise created by the increased outflow air speed in the connected fittings must be considered.

Flow rate range, minimum pressure difference

Nominal size $\varnothing D$ [mm]	at 1 m/s		at 2 m/s		at 4 m/s		at 7 m/s		at 10 m/s	
	V_{min} [m ³ /h]	V [m ³ /h]	Δp_{min} [Pa]	V [m ³ /h]	Δp_{min} [Pa]	V [m ³ /h]	Δp_{min} [Pa]	V_{nom} [m ³ /h]	Δp_{min} [Pa]	
100	27	54	10	109	15	190	20	272	50	
125	43	86		171		300		428	40	
160	71	141		282		494		706	40	
200	111	222		443		776		1108	40	

- V - Flow rate
- V_{min} - Minimum flow rate = lower limit of control
- V_{nom} - Nominal flow rate
- Δp_{min} - Minimum pressure loss

Technical brochure • Variable Flow Rate Controllers VRDactive

Application ranges and limits

- Minimum air speed 1 m/s
- Nominal air speed 10 m/s
- Maximum air speed in the free case section 12 m/s with specific factory-set adjustment
- Static over-pressure in the air duct based on ambient pressure up to 1000 Pa
- Static under-pressure in the air duct based on ambient pressure 750 Pa max.
- Leakage flow rate via closed damper blade Class 4 acc. to DIN EN 1751 (DN 100 and 125: Class 3)
- Leakage flow rate via casing Class A acc. to DIN EN 1751
- Ambient temperature range 0...+50 °C at 5...95 % rh, non-condensing (acc. to EN 60730-1)
- Suitable for low-pollution air flows (e. g. ETA1, ETA2 acc. to DIN EN 13779), non-corrosive, aggressive air, without solvents that may affect the EPDM damper sealing
- Installation with horizontal damper axle only
- Free suction with upstream air duct or via fitting only

Control accuracy

Deviations from the set value:

- ± 5 % at V_{nom} (equates to 10 m/s) up to
- ± 15 % at V_{min} (equates to 1 m/s).

Required straight inflow distances

A straight, undisturbed inflow distance of approx. $0,5...3 \times D$ in front of the flow rate controller is required. There are, however, no restrictions regarding the outflow side.

Please ensure a perfect positioning of the measuring nipples with respect to the air flow. Avoid turbulent air flow and short radius bends or T-branches before the damper.

Required straight inflow distance as minimum distance to the disturbance point: Min see illustration.

If a combination of fittings that is unfavourable with view to the air flow is unavoidable, the minimum distance is several times the given Min.

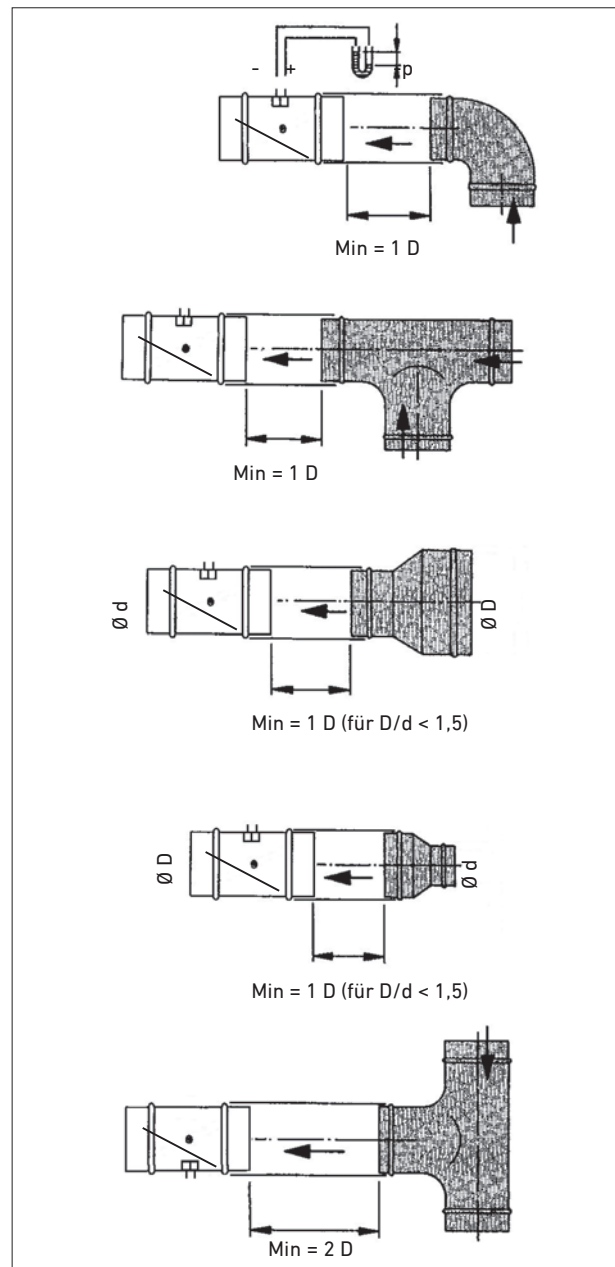

Technical brochure • Variable Flow Rate Controllers VRDactive

Dimensions, weights

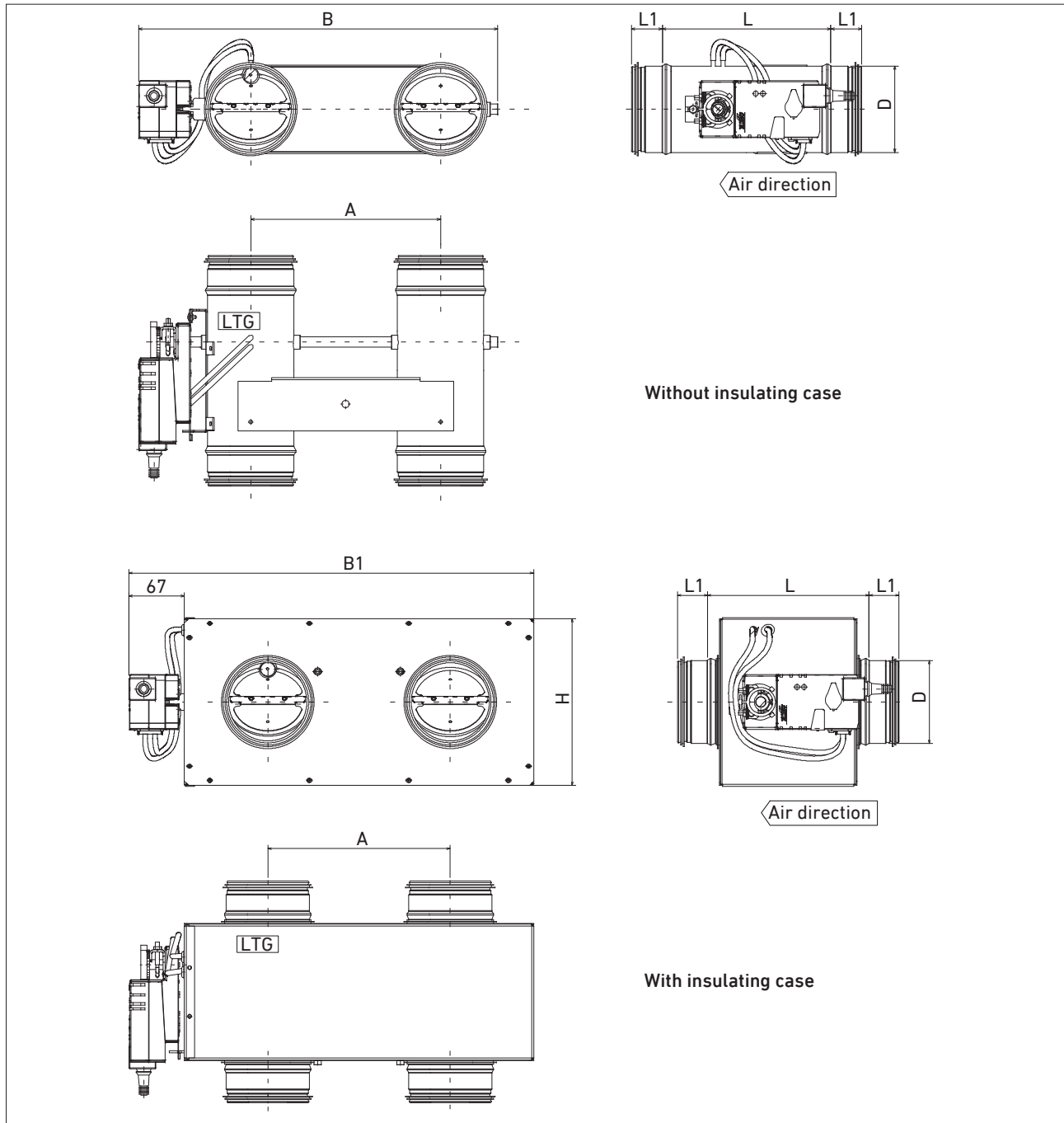

Nominal size Ø D	D [mm]	L [mm]	L1 [mm]	A [mm]	B [mm]	L [mm]	B1 [mm]	H [mm]	Damper angle [°]	Weight [kg]	
										with insulating case	without insulating case
100	99	195	36	220	416	195	488	199	60	3.2	7.5
125	124	195		245	466	195	538	224		4.0	10.0
160	159	215		280	559	215	607	259		4.6	11.5
200	199	215		320	616	215	686	298		5.8	14.5

Technical brochure • Variable Flow Rate Controllers VRDactive

Airborne sound transmission without sound absorber *

Nominal size Ø D	Air speed [m/s]	Flow rate [m³/h]	$\Delta p_{ges} = 100 \text{ Pa}$										$\Delta p_{ges} = 200 \text{ Pa}$									
			f_m [Hz]								Sum		f_m [Hz]								Sum	
			63	125	250	500	1 K	2 K	4 K	8 K	L_{WA} [dB(A)]	L_{WA} [dB(A)]	63	125	250	500	1 K	2 K	4 K	8 K	L_{WA} [dB(A)]	L_{WA} [dB(A)]
			L_W [dB/Okt]										L_W [dB/Okt]									
100	1	27	33	32	36	42	43	32	23	26	45	37	35	35	37	41	47	39	32	28	48	41
	4	108	39	48	44	42	41	35	31	27	45	37	42	51	50	48	50	46	47	42	54	46
	7	189	41	50	45	46	45	42	38	33	50	42	44	56	53	51	51	48	49	46	57	49
	10	272	44	51	48	50	49	47	42	43	54	46	47	58	56	55	54	53	49	52	60	52
125	1	43	32	29	31	39	41	32	23	16	42	35	37	29	33	41	49	44	37	29	51	43
	4	172	46	48	42	44	44	38	32	23	47	39	48	53	48	49	50	45	53	48	57	49
	7	299	50	54	48	49	50	42	40	36	53	45	52	61	54	54	55	49	53	51	60	52
	10	428	50	55	50	53	54	46	43	37	57	49	55	63	57	58	58	53	52	49	62	54
160	1	71	43	37	39	42	42	30	23	26	44	37	42	42	44	45	52	43	39	40	53	46
	4	284	49	50	46	46	46	36	29	26	48	41	52	54	53	52	53	46	39	34	55	48
	7	494	55	57	53	53	52	44	40	36	55	48	58	63	59	57	57	51	47	44	61	53
	10	706	58	60	56	57	57	49	45	40	60	51	62	66	63	61	61	55	51	49	65	56
200	1	111	38	33	37	40	39	31	21	15	42	34	41	37	41	46	49	45	36	28	51	44
	4	444	50	46	44	43	43	39	31	22	46	39	55	52	49	47	47	45	40	33	52	44
	7	776	58	53	50	50	51	46	40	37	54	44	62	59	57	54	54	51	47	48	58	49
	10	1108	65	60	58	57	57	53	48	54	61	51	66	63	61	58	58	56	51	56	63	52

Δp_{ges} - Total pressure difference

f_m - Octave mid-band frequency

L_W - Sound power level

L_{WA} - Sound power level, A-weighted

L_{pA} - Sound pressure level, A-weighted

* Data given refer to the half casing with installed compact controller.

For both half casings (supply and return air) the following applies: $L_{W \text{ total}} = L_W$ from the chart + 3 dB, with assumed identical sound source levels,

i.e. if the air speed and pressure loss in the supply air and return air duct are identical.

Technical brochure • Variable Flow Rate Controllers VRDactive

Airborne sound transmission with sound absorber type SDE-SO 900 mm long *

Nominal size Ø D	Air speed [m/s]	Flow rate [m³/h]	$\Delta p_{ges} = 100 \text{ Pa}$										$\Delta p_{ges} = 200 \text{ Pa}$									
			f_m [Hz]								Sum		f_m [Hz]								Sum	
			63	125	250	500	1 K	2 K	4 K	8 K	L_{WA} [dB(A)]	L_{WA} [dB(A)]	63	125	250	500	1 K	2 K	4 K	8 K	L_{WA} [dB(A)]	L_{WA} [dB(A)]
			L_W [dB/Okt]										L_W [dB/Okt]									
100	1	27	29	22	21	<15	<15	<15	<15	<15	16	<15	31	25	22	<15	<15	<15	<15	<15	17	<15
	4	108	33	28	25	17	<15	<15	<15	<15	20	<15	35	33	28	18	<15	<15	<15	<15	24	<15
	7	189	36	34	29	19	<15	<15	<15	<15	24	16	39	40	34	22	<15	<15	<15	17	30	20
	10	272	40	40	32	23	19	<15	<15	15	29	20	43	47	40	27	20	<15	<15	24	35	26
125	1	43	28	20	17	<15	<15	<15	<15	<15	<15	<15	33	20	19	<15	<15	<15	<15	<15	16	<15
	4	172	34	29	23	17	<15	<15	<15	<15	19	<15	39	31	27	20	<15	<15	<15	<15	24	<15
	7	299	40	37	29	21	<15	<15	<15	<15	27	17	45	42	35	25	<15	<15	<15	18	33	22
	10	428	46	45	35	26	21	17	<15	<15	33	24	51	53	42	31	22	17	17	24	40	30
160	1	71	40	32	28	19	<15	<15	<15	<15	23	<15	39	37	33	22	17	<15	<15	28	30	22
	4	284	45	40	34	24	<15	<15	<15	19	29	20	46	45	39	27	20	<15	<15	31	35	27
	7	494	50	47	39	29	18	<15	<15	23	35	26	52	53	45	33	23	<15	17	34	41	32
	10	706	55	55	45	34	25	19	17	27	42	31	59	61	52	38	28	21	21	36	48	37
200	1	111	37	28	27	21	<15	<15	<15	<15	22	<15	40	32	31	27	17	<15	20	17	28	21
	4	444	46	37	34	27	<15	<15	<15	17	29	21	48	41	38	31	20	18	25	26	34	26
	7	776	55	46	41	32	20	16	23	30	37	27	57	49	44	35	23	21	30	35	40	31
	10	1108	64	55	48	38	28	24	32	43	46	34	65	58	51	39	28	26	35	45	48	37

Δp_{ges} - Total pressure difference

f_m - Octave mid-band frequency

L_W - Sound power level

L_{WA} - Sound power level, A-weighted

L_{pA} - Sound pressure level, A-weighted

* Data given refer to the half casing with installed compact controller.

For both half casings (supply and return air) the following applies: $L_{W \text{ total}} = L_W$ from the chart + 3 dB, with assumed identical sound source levels,

i.e. if the air speed and pressure loss in the supply air and return air duct are identical.

Technical brochure • Variable Flow Rate Controllers VRDactive

Casing sound emission without insulating case *

Nominal size Ø D	Air speed [m/s]	Flow rate [m³/h]	$\Delta p_{ges} = 100 \text{ Pa}$										$\Delta p_{ges} = 200 \text{ Pa}$									
			f_m [Hz]								Sum		f_m [Hz]								Sum	
			63	125	250	500	1 K	2 K	4 K	8 K	L_W [dB(A)]	L_{WA} [dB(A)]	63	125	250	500	1 K	2 K	4 K	8 K	L_W [dB(A)]	L_{WA} [dB(A)]
			L_W [dB/Okt]										L_W [dB/Okt]									
100	1	27	20	<15	18	25	28	23	<15	15	30	21	22	<15	19	23	31	31	20	17	35	26
	4	108	26	24	26	25	26	27	19	16	31	22	30	26	33	31	34	37	36	31	42	33
	7	189	28	25	28	28	30	34	26	23	37	28	31	31	36	34	36	40	38	36	45	36
	10	272	32	27	31	33	34	39	31	33	42	33	34	33	38	37	39	44	38	42	48	39
125	1	43	18	<15	<15	21	24	23	<15	<15	28	19	23	<15	<15	23	33	35	25	17	38	29
	4	172	33	23	24	26	27	29	19	<15	33	24	35	28	30	31	34	36	41	37	44	36
	7	299	37	29	29	31	33	33	27	25	38	29	39	36	36	36	38	40	41	40	47	38
	10	428	37	30	32	35	38	37	31	26	42	33	42	37	39	40	42	43	40	37	48	39
160	1	71	29	<15	20	23	25	20	<15	16	27	19	28	16	25	26	35	33	26	30	38	30
	4	284	35	24	27	27	29	26	16	16	32	23	38	28	34	33	36	36	26	24	40	32
	7	494	41	31	34	34	35	34	27	26	39	31	44	37	40	38	40	41	34	34	45	37
	10	706	44	34	37	38	40	39	32	30	44	35	48	40	44	42	44	45	38	39	49	41
200	1	111	28	<15	22	25	23	17	<15	<15	26	17	31	17	27	30	33	30	22	19	36	27
	4	444	40	27	30	28	27	24	16	<15	31	22	45	32	35	32	31	31	25	24	37	28
	7	776	48	34	36	35	35	31	26	28	39	30	52	40	43	39	37	37	33	39	44	35
	10	1108	55	41	44	42	41	39	34	45	48	39	56	44	47	43	42	41	36	47	50	41

Δp_{ges} - Total pressure difference

f_m - Octave mid-band frequency

L_W - Sound power level

L_{WA} - Sound power level, A-weighted

L_{pA} - Sound pressure level, A-weighted

Casing sound emission data given in the chart refer to the emitting jacket surface of a duct of galvanized sheet steel, total length 6 m, with the flow rate controller installed.

Due to resonance effects given frequency-related sound power level data may vary ± 6 dB max.

* Data given refer to the half casing with installed compact controller.

For both half casings (supply and return air) the following applies: $L_{W \text{ total}} = L_W$ from the chart + 3 dB, with assumed identical sound source levels,

i.e. if the air speed and pressure loss in the supply air and return air duct are identical.

Technical brochure • Variable Flow Rate Controllers VRDactive

Casing sound emission with 50 mm insulating case *

Nominal size Ø D	Air speed [m/s]	Flow rate [m³/h]	$\Delta p_{ges} = 100 \text{ Pa}$										$\Delta p_{ges} = 200 \text{ Pa}$									
			f_m [Hz]								Sum		f_m [Hz]								Sum	
			63	125	250	500	1 K	2 K	4 K	8 K	L_{WA} [dB(A)]	L_{WA} [dB(A)]	63	125	250	500	1 K	2 K	4 K	8 K	L_{WA} [dB(A)]	L_{WA} [dB(A)]
			L_W [dB/Okt]										L_W [dB/Okt]									
100	1	27	19	<15	18	19	19	<15	<15	<15	21	12	21	<15	19	17	22	<15	<15	<15	23	14
	4	108	25	24	26	19	17	<15	<15	<15	22	13	29	26	33	25	25	16	16	<15	29	20
	7	189	27	25	28	22	21	<15	<15	<15	25	16	30	31	36	28	27	19	18	16	32	23
	10	272	31	27	31	27	25	18	<15	<15	29	20	33	33	38	31	30	23	18	22	35	26
125	1	43	17	<15	18	17	16	<15	<15	<15	19	9	22	<15	<15	17	24	<15	<15	<15	25	15
	4	172	32	23	24	20	18	<15	<15	<15	22	13	34	28	30	25	25	15	21	17	29	20
	7	299	36	29	29	25	24	<15	<15	<15	28	18	38	36	36	30	29	19	21	20	34	25
	10	428	36	30	32	29	29	16	<15	<15	32	23	41	37	39	34	33	22	20	17	37	28
160	1	71	28	<15	20	17	16	<15	<15	<15	19	10	27	16	25	20	26	<15	<15	<15	27	18
	4	284	34	24	27	21	20	<15	<15	<15	24	15	37	28	34	27	27	<15	<15	<15	30	21
	7	494	40	31	34	28	26	<15	<15	<15	30	21	43	37	40	32	31	20	<15	<15	35	27
	10	706	43	34	37	32	31	18	<15	<15	34	26	47	40	44	36	35	24	18	17	39	31
200	1	111	25	<15	20	22	20	<15	<15	<15	23	14	28	15	25	27	30	24	<15	<15	32	23
	4	444	37	25	28	25	24	18	<15	<15	28	19	42	30	33	29	28	25	<15	<15	32	23
	7	776	45	32	34	32	32	25	<15	<15	35	26	49	38	41	36	34	31	<15	18	39	30
	10	1108	52	39	42	39	38	33	<15	24	42	33	53	42	45	40	39	35	<15	26	43	35

Δp_{ges} - Total pressure difference

f_m - Octave mid-band frequency

L_W - Sound power level

L_{WA} - Sound power level, A-weighted

L_{pA} - Sound pressure level, A-weighted

Casing sound emission data given in the chart refer to the emitting jacket surface of a duct of galvanized sheet steel, total length 6 m, with the flow rate controller installed. Both the flow rate controller and the duct are provided with a 50 mm insulating case.

Due to resonance effects given frequency-related sound power level data may vary by ± 6 dB max.

* Data given refer to the half casing with installed compact controller.

For both half casings (supply and return air) the following applies: $L_{W \text{ total}} = L_W$ from the chart + 3 dB, with assumed identical sound source levels,

i.e. if the air speed and pressure loss in the supply air and return air duct are identical.

Technical brochure • Variable Flow Rate Controllers VRDactive

Room sound pressure level calculation from controller sound transmission * (excluding flow noise from the air diffusers)

System attenuation according to VDI 2081

f_m	[Hz]	63	125	250	500	1000	2000	4000	8000
Deflection $\Delta L_{W Okt}$	[dB/Okt]	0	0	1	2	3	3	3	3
Room attenuation $\Delta L_{W Okt}$	[dB/Okt]	5	5	5	5	5	5	5	5
Outlet reflection $\Delta L_{W Okt}$	[dB/Okt]	10	5	2	0	0	0	0	0

Branching attenuation for distributing the sound power over multiple rooms, $V_{room} = 540 \text{ m}^3/\text{h}$

V	[m ³ /h]	540	1080	2160	5400	10800	16200	21600	25200	28800	32400	36000
$\Delta L_{W Okt} = 10 \times Lg \frac{V}{540 \text{ m}^3/\text{h}}$	[dB/Okt]	0	3	6	10	13	14	16	17	17	18	19

Sample calculation sound transmission

Given : VRDactive 200 with silencer type SDE-SO 900 mm long

$$V_{max} = 444 \text{ m}^3/\text{h}, \text{ equates to } 4 \text{ m/s}$$

$$\Delta p_{ges} = 200 \text{ Pa}$$

$$L_{WA} = 34 \text{ dB(A)}$$

Required: Room sound pressure level L_{pA} from controller sound transmission

Solution: f_m	[Hz]	63	125	250	500	1000	2000	4000	8000	Source
Sound power level $L_{W Okt}$	[dB/Okt]	48	41	38	31	20	18	25	26	p. 9
Deflection $\Delta L_{W Okt}$	[dB/Okt]	0	0	-1	-2	-3	-3	-3	-3	p. 12
Room attenuation $\Delta L_{W Okt}$	[dB/Okt]	-5	-5	-5	-5	-5	-5	-5	-5	p. 12
Outlet reflection $L_{W Okt}$	[dB/Okt]	-10	-5	-2	0	0	0	0	0	p. 12
Branching attenuation										
$\Delta L_{W Okt} = 10 \times Lg \frac{444 \text{ m}^3/\text{h}}{540 \text{ m}^3/\text{h}}$	[dB/Okt]	0	0	0	0	0	0	0	0	p. 12
A-weighting $\Delta L_{W Okt}$	[dB/Okt]	-26	-16	-9	-3	0	1	1	-1	
A-weighted sound pressure level $L_{pA Okt}$	[dB(A)/Okt]	<15	<15	20	21	<15	<15	17	16	
A-weighted sum sound pressure level $L_{pA} = 26 \text{ dB(A)}$										

* Data given refer to the duct with installed compact controller.

Technical brochure • Variable Flow Rate Controllers VRDactive

Room sound pressure level calculation from controller radiation

f_m		[Hz]	63	125	250	500	1000	2000	4000	8000
Ceiling attenuation	$\Delta L_{W Okt}$	[dB/Okt]	4	4	4	4	4	4	4	4
Room attenuation	$\Delta L_{W Okt}$	[dB/Okt]	5	5	5	5	5	5	5	5

Sample calculation radiation

Given: VRDactive 200 without insulating case

$V_{max} = 444 \text{ m}^3/\text{h}$, equates to 4 m/s

$\Delta p_{ges} = 200 \text{ Pa}$

$L_{WA} = 37 \text{ dB(A)}$

Required: Room sound pressure level L_{pA} from controller radiation

Solution:

f_m		[Hz]	63	125	250	500	1000	2000	4000	8000	Source
Sound power level	$L_{W Okt}$	[dB/Okt]	45	32	35	32	31	31	25	24	p. 10
Ceiling attenuation	$\Delta L_{W Okt}$	[dB/Okt]	-4	-4	-4	-4	-4	-4	-4	-4	p. 12
Room attenuation	$\Delta L_{W Okt}$	[dB/Okt]	-5	-5	-5	-5	-5	-5	-5	-5	p. 12
A-weighting	$\Delta L_{W Okt}$	[dB/Okt]	-26	-16	-9	-3	0	1	1	-1	
A-weighted sound pressure level	$L_{pA Okt}$	[dB(A)/Okt]	<15	<15	17	20	22	23	17	<15	
A-weighted sum sound pressure level $L_{pA} = 25 \text{ dB(A)}$											

Technical brochure • Variable Flow Rate Controllers VRDactive

Nomenclature, ordering code

VRDactive 100 / S / D / - / A / B 671

(1) (2) (3) (4) (5) (6) (7) (8) (9)

(1) Type	VRDactive	= Twin flow rate controller, round, short, with map control
(2) Measuring principle		= dynamic
	-S	= static
(3) Size	100	= 100
	125	= 125
	160	= 160
	200	= 200
(4) Version	S	= galvanized steel
	E	= stainless steel V4A
	K	= coated
(5) Insulating case	D	= with
	-	= without
(6) Connection	-	= Plug-in end piece without lip seal gasket
	L	= Plug-in end piece with lip seal gasket
	F	= Flanges acc. to DIN 24154 R1
	B	= Bord
(7) Leakage flow rate via casing	A	= Class A acc. to DIN EN 1751 (standard)
	C	= Class C acc. to DIN EN 1751
(8) Compact controller (make)	B	= Belimo
	G	= Gruner
(9) Compact controller (type)	671	= Belimo LMV-D3W-MF-F (standard, analogue / continuous activation)
	670	= Belimo LMV-D3W-MP-F (compatible with MP-Bus, with NFC interface)
	672	= Belimo LMV-D3W-MOD-F (compatible with Modbus and BACnet)
	227-05	= Gruner 227VMZ-024-05-DS6 (static)

Additional ordering specifications

Please specify when ordering

- V_{\min} [m ³ /h]	Please note:
- V_{\max} [m ³ /h]	
- Mode: 0...10 V oder 2...10 V	
- $V_{\min} \geq 0$ m ³ /h	
- $V_{\min} \leq V_{\max}$	
- $V_{\max} \leq V_{\text{nom}}$	
- $V_{\max} \geq 0,2 V_{\text{nom}}$	

In the absence of such specifications the unit will be delivered with the following factory settings:









- $V_{\min} = 0$ m ³ /h
- $V_{\max} = V_{\text{nom}}$
- Mode = 0...10 V

Ordering example

VRDactive 100/S/D/-/A/B671, $V_{\min} = 100$ m³/h, $V_{\max} = 200$ m³/h, Mode 2...10 V

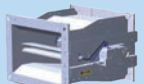

Product Overview • LTG Air Distribution

Flow rate controllers

		Circular		Square		
Variable		VREactive	LTG Map Control System <i>ActiveControl</i> . Highest precision, short installation length		VRFactive	LTG Map Control System <i>ActiveControl</i> . Highest precision, short installation length
		VRDactive			VRFvent	
		VRE	To combine with customized drives; VRE also available in PPs			
		VRD				
Constant		VRW	Without external power supply, pollution-insensitive		VRX	Without external power supply; pollution-insensitive
		VRZ				

All variable controllers are available with dynamic or static measuring principle.

Pressure controllers

		Circular	Square		
	DRE DREactive	To balance extreme pressure level differences; with flow rate measurement (optional)		DRF DRFactive	To balance extreme pressure level differences; with flow rate measurement (optional)

Shut-off units

		Circular	Square		
	KLB	Ultra-tight shut-off damper		ARF	Airtight shut-off damper
	ARE	Airtight shut-off damper			

Air-tight shut-off acc. to DIN EN 175: up to Class 4

Engineering Services



LTG Engineering Services Comfort Air Technology

Portfolio

For our complete portfolio of air distribution products with suitable accessories see <https://www.ltg.de/en/products-services/ltg-comfort-air-technology/air-distribution/>



**AIR TECH
SYSTEMS**

Comfort Air Technology

Air-Water Systems
Air Diffusers
Air Distribution

Process Air Technology

Fans
Filtration Technology
HumidificationTechnology

Engineering Services

Laboratory Test & Experiment
Field Measurement & Optimisation
Simulation & Expertise
R&D & Start-up

LTG Aktiengesellschaft

Grenzstrasse 7
70435 Stuttgart
Germany
Tel.: +49 711 8201-0
Fax: +49 711 8201-720
E-Mail: info@LTG.net
www.LTG.net

LTG Incorporated

105 Corporate Drive, Suite E
Spartanburg, SC 29303
USA
Tel.: +1 864 599-6340
Fax: +1 864 599-6344
E-Mail: info@LTG-INC.net
www.LTG-INC.net