



Technical catalogue

We care about healthy air

**Climmy TopLine**

fan coil units

## **CONTENTS**

### **TopLine**

- Introduction *Page 3*
- Main components *Page 4*
- Technical features *Page 5*
- Emissions *Page 6*
- Water side pressure drop *Page 9*
- Working conditions *Page 9*
- Dimensions and weights *Page 10*
- Air throw *Page 12*
- Fresh air supply *Page 13*
- Air distribution *Page 13*
- Accessories *Page 14*
- Electrostatic filter *Page 20*
- Wall electronic controls *Page 24*
- Controls for **TL-MB** versions *Page 28*
- Electric heater **TL-E** *Page 29*

### **TopLine ECM**

- Introduction *Page 30*
- Main components *Page 31*
- Technical features *Page 32*
- Emissions *Page 34*
- Water side pressure drop *Page 38*
- Working conditions *Page 39*
- Dimensions and weights *Page 40*
- Air throw *Page 42*
- Accessories *Page 43*
- **TL-ECM** configuration *Page 45*
- Wall electronic controls *Page 46*
- Controls for **TL-ECM-MB** versions *Page 48*
- Electric heater **TL-ECM-E** *Page 49*

### **TopLine / TopLine ECM**

- **MB** electronic board *Page 50*
- **T-MB** wall control *Page 51*
- **RT03** infra-red remote control *Page 52*
- **PSM-DI** multifunction control *Page 54*
- **NET** management system *Page 55*
- PSM-DI and NET accessories *Page 59*

### **TopLine MCT**

- Introduction *Page 60*
- Dimensions and weights *Page 61*
- Assembly diagram *Page 62*
- Components of the casing e Valve kit *Page 63*

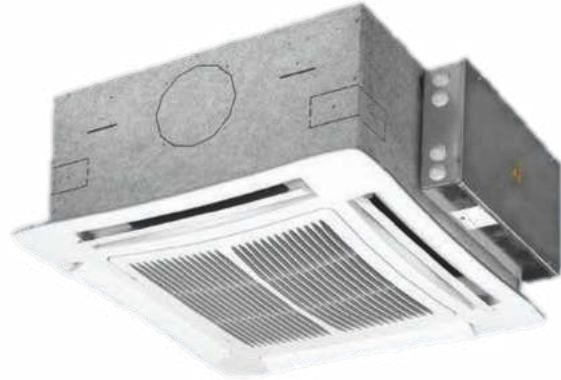

**MD-600 Version**



Innovating and beautiful design, seven different sizes, high control flexibility, easy maintenance: the new TopLine chilled water cassette is the result of an extended technical and design development aimed at achieving the highest level in terms of performance, silent operation and control possibilities.

The air diffuser has an highly attractive aesthetical appearance, very innovative, and is also able to offer the best air distribution performance thanks to in-depth computer studies and laboratory tests. The standard colour is RAL 9003, other colours available on request.

The 4 smaller sizes are designed to fit into 600x600 mm false ceiling standard modules. The 3 bigger sizes have a dimension of 800x800 mm which allows the best outcome in terms of quietness and of price/performance ratio for these high capacity models.

Every unit can be supplied with 1 battery (2 pipe system) and a possible electric heater or with 2 batteries (4 pipe system). Each model can have fresh air intake and a remote air diffuser can be connected to the unit.

The condensate pump is integral with the unit, is very quiet and has a maximum head of 650 mm.

In addition to temperature and speed standard controls, automatic speed selection is also available. More than one unit can be connected to a single control, and the unit control panel can be installed in a remote position that facilitates the maintenance operation. All the TopLine units can be supplied in MB version. This version allows a wide range of controls, including the infra-red remote control, which can manage one single unit or several units by using the Modbus RTU - RS 485 communication protocol.

The units can be connected to the most common automatic building management systems.

Finally, each unit can be equipped with a low energy consumption electric motor that is controlled by an inverter card that makes possible continuous air flow variations.



## Main components

---

### INTAKE GRID AND DISTRIBUTION OF THE AIR

Intake grids, frame and adjustable air distribution louvers on each side, made from ABS.

*RSNA version:* white ABS, RAL 9003

*RSNB version:* with intake grid, frame and louvers, choice of one colour only

*RSNC version:* with intake grid and louvers, choice of one colour, plus white ABS frame RAL 9003

*RSND version:* with louvers, choice of one colour, while the grid and frame are made from ABS, RAL 9003

*MD-600 version/MD-800 version:* metal diffuser painted in RAL 9003 white colour with 600x600 dimension to perfectly fit into the false ceiling standard modules without overlapping parts.

### CASING

Is made from galvanized steel with internal thermal insulation with polyolefin (PO) foam (class M1) and external anti-condensate lining.

### CONTROL PANEL

Made of an external box with the control electronic board with an easily accessible terminal board.

### FAN ASSEMBLY

The fan assembly, which is mounted on anti-vibrating supports, is extremely silent.

The radial fan has been designed to optimise performance, using wing profile blades with a shape that reduces turbulence, increasing efficiency and reducing noise.

The single air inlet radial fan is connected to a 6 speed electric motor with single phase 230V/50Hz supply, class B insulation and integrated Klixon thermal contact for motor protection.

The units are supplied with 3 standard speeds connected and it is possible to change them on site if necessary.

### COIL

Made of copper tubes with bonded aluminium fins for maximum transfer contact.

The coil has 1, 2 or 3 rows for 2 pipe models and 2+1 rows for 4 pipe models (the heating row is on the inside part of the coil).

For 4 pipe systems two versions are available:

TL 0.4T, TL 1.4T, TL 2.4T, TL 3.4T, TL 4.4T, TL 5.4T, TL 6.4T supply an higher heating emission;

TL 2.6T, TL 3.6T, TL 5.6T, TL 6.6T supply an higher cooling emission.

The heat exchanger is not suitable for use in corrosive atmosphere or in environments where aluminium may be subject to corrosion.

### CONDENSATE COLLECTION TRAY

High density ABS polystyrene foam condensate tray, shaped in order to optimize the air diffusion, fire retardant rating B1 to DIN 4102.

### AIR FILTER

Synthetic washable filter, easily removable.

### CONDENSATE PUMP

Float switch centrifugal pump with 650 mm of maximum head, integral to the unit and wired to the control panel on the outside of the casing.

### VALVE SET

Two or three way valves for ON/OFF operation, with pipe mounting kit and thermostatic actuator.

**2 pipe units.** The following standard rating conditions are used:

## COOLING

Entering air temperature +27°C d.b. +19°C w.b.  
Water temperature +7°C E.W.T. +12°C L.W.T.

## HEATING

Entering air temperature +20°C  
Water temperature +45°C E.W.T. +40°C L.W.T.

<b>MODEL</b>		<b>TL 0.2T</b>			<b>TL 1.2T</b>			<b>TL 2.2T</b>			<b>TL 3.2T</b>			<b>TL 4.2T</b>			<b>TL 5.2T</b>			<b>TL 6.2T</b>		
<b>Speed</b>		1	2	3	1	2	3	1	2	3	1	2	3	1	2	3	1	2	3	1	2	3
Air flow	m <sup>3</sup> /h	310	420	610	310	420	520	320	500	710	430	610	880	630	820	1140	710	970	1500	710	1280	1820
Cooling total emission	kW	1,25	1,60	1,92	1,82	2,31	2,64	2,23	3,30	4,26	2,91	3,82	4,93	4,18	4,86	6,08	5,27	6,72	9,39	5,27	8,36	10,93
Cooling sensible emission	kW	0,99	1,29	1,58	1,33	1,72	2,00	1,55	2,35	3,11	2,05	2,75	3,65	3,00	3,53	4,51	3,42	4,42	6,36	3,67	6,00	8,08
Heating	kW	1,38	1,80	2,24	1,85	2,42	2,80	2,12	3,28	4,37	2,85	3,85	5,15	4,27	5,03	6,50	4,92	6,40	9,23	5,12	8,55	11,72
Dp Cooling	kPa	4,5	7,0	10,0	4,9	7,6	9,7	6,4	13,0	20,9	7,5	12,4	19,7	10,9	14,3	21,6	9,4	14,7	26,9	9,4	21,8	35,6
Dp Heating	kPa	4,4	7,2	10,7	4,3	6,9	9,0	2,8	6,1	10,2	6,2	10,6	17,8	7,0	9,4	15,0	7,1	11,4	22,0	7,6	19,2	33,8
Sound power Lw	dB(A)	33	40	49	33	40	45	33	45	53	41	49	59	33	40	48	34	40	53	34	48	58
Sound pressure Lp (*)	dB(A)	24	31	40	24	31	36	24	36	44	32	40	50	24	31	39	25	31	44	25	39	49
Fan	W	25	32	57	25	32	44	25	44	68	32	57	90	33	48	77	42	63	120	42	95	170
	A	0,11	0,15	0,27	0,11	0,15	0,20	0,11	0,20	0,32	0,15	0,27	0,45	0,15	0,23	0,36	0,18	0,28	0,53	0,18	0,42	0,74
Water content	l	0,8			1,4			2,1			2,1			3,0			4,0			4,0		
Dimensions	mm	575 x 575 x 275												820 x 820 x 303								

**4 pipe units.** The following standard rating conditions are used:

## COOLING

Entering air temperature +27°C d.b. +19°C w.b.  
Water temperature +7°C E.W.T. +12°C L.W.T.

## HEATING

Entering air temperature +20°C  
Water temperature +65°C E.W.T. +55°C L.W.T.

<b>MODEL</b>		<b>TL 0.4T</b>			<b>TL 1.4T</b>			<b>TL 2.4T</b>			<b>TL 2.6T</b>			<b>TL 3.4T</b>			<b>TL 3.6T</b>		
<b>Speed</b>		1	2	3	1	2	3	1	2	3	1	2	3	1	2	3	1	2	3
Air flow	m <sup>3</sup> /h	310	420	610	310	420	520	310	500	710	320	500	710	430	610	880	430	610	880
Cooling total emission	kW	1,49	1,93	2,27	1,83	2,33	2,66	1,83	2,61	3,27	2,07	3,02	3,86	2,33	2,96	3,72	2,69	3,47	4,44
Cooling sensible emission	kW	1,13	1,52	1,84	1,32	1,68	1,94	1,32	1,94	2,49	1,47	2,20	2,88	1,72	2,23	2,88	1,94	2,56	3,37
Dp Cooling	kPa	6,0	10,0	13,5	4,6	6,9	8,8	4,6	8,8	13,4	4,0	7,0	10,5	7,2	11,2	17,0	6,0	9,0	14,0
Heating	kW	1,72	2,23	2,66	2,13	2,66	3,04	2,13	3,04	3,86	1,73	2,71	2,91	2,61	3,33	4,19	2,14	2,66	3,29
Dp Heating	kPa	5,2	8,3	11,4	4,6	6,8	8,7	4,6	8,7	13,3	2,6	4,6	6,7	6,4	9,9	15,0	3,9	5,7	8,4
Sound power Lw	dB(A)	33	40	49	33	40	45	33	45	53	33	45	53	41	49	59	41	49	59
Sound pressure Lp (*)	dB(A)	24	31	40	24	31	36	24	36	44	24	36	44	32	40	50	32	40	50
Fan	W	25	32	57	25	32	44	25	44	68	25	44	68	32	57	90	32	57	90
	A	0,11	0,15	0,27	0,11	0,15	0,20	0,11	0,20	0,32	0,11	0,20	0,32	0,15	0,27	0,45	0,15	0,27	0,45
Cooling water content	l	1,0			1,4			1,4			1,7			1,4			1,7		
Heating water content	l	0,6			0,7			0,7			0,5			0,7			0,5		
Dimensions	mm	575 x 575 x 275																	

<b>MODEL</b>		<b>TL 4.4T</b>			<b>TL 5.4T</b>			<b>TL 5.6T</b>			<b>TL 6.4T</b>			<b>TL 6.6T</b>		
<b>Speed</b>		1	2	3	1	2	3	1	2	3	1	2	3	1	2	3
Air flow	m <sup>3</sup> /h	630	820	1140	710	970	1500	710	970	1500	710	1280	1820	710	1225	1730
Cooling total emission	kW	4,11	4,98	6,26	4,48	5,60	7,59	4,95	6,27	8,65	4,48	6,84	8,72	4,95	7,75	9,69
Cooling sensible emission	kW	2,93	3,60	4,61	3,21	4,09	5,71	3,49	4,49	6,37	3,21	5,09	6,67	3,49	5,64	7,26
Dp Cooling	kPa	8,8	12,5	18,9	10,3	15,4	26,9	9,0	14,0	25,0	10,3	22,1	34,7	9,0	20,0	32,0
Heating	kW	5,21	6,33	8,02	5,69	7,15	9,66	4,59	5,63	7,50	5,69	8,80	11,16	4,59	6,78	9,48
Dp Heating	kPa	7,9	11,2	17,2	9,3	14,0	24,0	4,9	7,0	11,8	9,3	20,3	31,2	4,9	9,9	15,0
Sound power Lw	dB(A)	33	40	48	34	40	53	34	40	53	34	48	58	34	48	58
Sound pressure Lp (*)	dB(A)	24	31	39	25	31	44	25	31	44	25	39	49	25	39	49
Fan	W	33	48	77	42	63	120	42	63	120	42	95	170	42	95	170
	A	0,15	0,23	0,36	0,18	0,28	0,53	0,18	0,28	0,53	0,18	0,42	0,74	0,18	0,42	0,74
Cooling water content	l	3,0			3,0			3,6			3,0			3,6		
Heating water content	l	1,4			1,4			1,0			1,4			1,1		
Dimensions	mm	820 x 820 x 303														

### Condensate pump absorption: 10 W

(\*) = The sound pressure levels are 9 dB(A) lower than the sound power levels and apply to the reverberant field of a 100 m<sup>3</sup> room and a reverberation time of 0.5 sec.

Cooling emission of 1 battery units (2 pipe installation)

Entering air temperature: +27°C d.b. – +19°C w.b.

Mod.	Speed	Qv m³/h	WT: 5/10 °C				WT: 7/12 °C			WT: 9/14 °C			WT: 12/17 °C		
			Qw l/h	Pc kW	Ps kW	Qw l/h	Pc kW	Ps kW	Qw l/h	Pc kW	Ps kW	Qw l/h	Pc kW	Ps kW	
TL 0.2T	MAX	610	421	2,39	1,77	340	1,92	1,58	254	1,41	1,39	199	1,10	1,10	
	MED	420	346	1,98	1,45	280	1,60	1,29	210	1,22	1,16	160	0,90	0,90	
	MIN	310	269	1,55	1,12	219	1,25	0,99	165	0,96	0,89	123	0,69	0,69	
TL 1.2T	MAX	520	554	3,18	2,18	462	2,64	2,00	362	2,10	1,75	252	1,43	1,43	
	MED	420	482	2,77	1,88	403	2,31	1,72	317	1,84	1,50	220	1,25	1,25	
	MIN	310	417	2,40	1,62	317	1,82	1,30	276	1,61	1,29	188	1,07	1,07	
TL 2.2T	MAX	710	926	5,31	3,57	745	4,26	3,11	617	3,59	2,87	420	2,37	2,37	
	MED	500	715	4,11	2,73	575	3,30	2,35	483	2,81	2,18	319	1,82	1,82	
	MIN	320	508	2,93	1,92	387	2,23	1,55	349	2,03	1,53	225	1,29	1,29	
TL 3.2T	MAX	880	1049	6,01	4,08	863	4,93	3,65	694	4,03	3,29	479	2,70	2,70	
	MED	610	835	4,79	3,20	667	3,82	2,75	559	3,25	2,57	376	2,13	2,13	
	MIN	430	633	3,65	2,41	506	2,91	2,05	430	2,50	1,92	283	1,62	1,62	
TL 4.2T	MAX	1140	1264	7,27	4,92	1060	6,08	4,40	840	4,88	3,95	573	3,25	3,25	
	MED	820	1003	5,78	3,87	845	4,86	3,45	674	3,92	3,09	453	2,58	2,58	
	MIN	630	858	4,96	3,29	722	4,18	2,94	580	3,37	2,62	384	2,20	2,20	
TL 5.2T	MAX	1500	1943	11,18	7,47	1635	9,39	6,36	1301	7,57	5,99	880	5,00	5,00	
	MED	970	1374	7,93	5,21	1166	6,72	4,42	939	5,46	4,15	612	3,50	3,50	
	MIN	710	1070	6,18	4,02	913	5,27	3,42	740	4,30	3,20	434	2,48	2,48	
TL 6.2T	MAX	1820	2277	13,07	8,84	1909	10,93	7,90	1511	8,78	7,11	1044	5,90	5,90	
	MED	1280	1722	9,92	6,59	1454	8,36	5,89	1162	6,75	5,27	775	4,42	4,42	
	MIN	710	1070	6,18	4,02	913	5,27	3,60	740	4,30	3,20	434	2,48	2,48	

Heating emission of 1 battery units (2 pipe installation)

Entering air temperature: +20°C

Mod.	Speed	Qv m³/h	WT: 45/40 °C		WT: 50/40 °C		WT: 60/50 °C		WT: 70/60 °C		WT: 80/70 °C	
			Qw l/h	Ph kW	Qw l/h	Ph kW	Qw l/h	Ph kW	Qw l/h	Ph kW	Qw l/h	Ph kW
TL 0.2T	MAX	610	386	2,24	203	2,37	298	3,46	393	4,56	488	5,67
	MED	420	310	1,80	164	1,91	239	2,78	315	3,66	391	4,55
	MIN	310	237	1,38	126	1,46	183	2,13	240	2,80	298	3,47
TL 1.2T	MAX	520	482	2,80	266	3,10	377	4,39	488	5,68	599	6,97
	MED	420	417	2,42	232	2,69	327	3,80	422	4,91	513	5,96
	MIN	310	356	2,07	198	2,31	279	3,25	360	4,19	441	5,12
TL 2.2T	MAX	710	787	4,57	440	5,12	619	7,19	795	9,25	972	11,30
	MED	500	593	3,45	334	3,89	467	5,43	598	6,96	730	8,48
	MIN	320	412	2,39	235	2,73	326	3,79	415	4,83	505	5,87
TL 3.2T	MAX	880	903	5,25	504	5,86	709	8,25	914	10,63	1118	13,00
	MED	610	702	4,08	394	4,58	552	6,42	709	8,25	866	10,07
	MIN	430	520	3,02	294	3,42	410	4,77	524	6,10	639	7,43
TL 4.2T	MAX	1140	1118	6,50	624	7,26	878	10,21	1130	13,14	1383	16,08
	MED	820	865	5,03	486	5,65	681	7,92	874	10,16	1067	12,41
	MIN	630	734	4,27	415	4,82	578	6,72	741	8,61	903	10,50
TL 5.2T	MAX	1500	1683	9,78	951	11,06	1327	15,43	1699	19,76	2071	24,08
	MED	970	1146	6,67	655	7,62	906	10,54	1155	13,43	1403	16,32
	MIN	710	876	5,09	505	5,87	694	8,07	882	10,25	1068	12,42
TL 6.2T	MAX	1820	2015	11,72	1132	13,17	1586	18,45	2037	23,68	2486	28,91
	MED	1280	1471	8,55	834	9,70	1161	13,50	1484	17,26	1807	21,01
	MIN	710	876	5,09	505	5,87	694	8,07	882	10,25	1068	12,42

Emission correction factors for different working conditions

Multiply the factors by the emission figures in the 7-12°C table above.

Note: the correction factors are indicative, as they are average values.

Water (°C)	Air (°C)	TOTAL EMISSION			Air (°C)	SENSIBLE EMISSION		
		25 - 18	26 - 18.5	28 - 20		25 - 18	26 - 18.5	28 - 20
7/12	K	0,82	0,89	1,11	K	0,90	0,94	1,06
10/15	K	0,56	0,63	0,82	K	0,72	0,78	0,90
14/18	K	0,35	0,41	0,52	K	0,50	0,58	0,72

LEGEND

- WT = Water temperature
- Pc = Cooling total emission
- Ps = Cooling sens. emission
- Ph = Emission
- Qw = Water flow
- Speed = Fan speed
- MAX = High speed
- MED = Medium speed
- MIN = Low speed
- Qv = Air flow

Cooling emission of 2 battery units (4 pipe installation)

Entering air temperature: +27°C d.b. – +19°C w.b.

		WT: 5/10 °C				WT: 7/12 °C			WT: 9/14 °C			WT: 12/17 °C		
Mod.	Speed	Qv	Qw	Pc	Ps	Qw	Pc	Ps	Qw	Pc	Ps	Qw	Pc	Ps
		m³/h	l/h	kW	kW	l/h	kW	kW	l/h	kW	kW	l/h	kW	kW
TL 0.4T	MAX	610	490	2,79	2,06	401	2,27	1,84	307	1,78	1,69	239	1,33	1,33
	MED	420	410	2,35	1,70	337	1,93	1,52	260	1,51	1,37	196	1,11	1,11
	MIN	310	314	1,80	1,27	260	1,49	1,13	201	1,17	1,02	148	0,84	0,84
TL 1.4T	MAX	520	569	3,27	2,22	465	2,66	1,94	374	2,18	1,79	260	1,47	1,47
	MED	420	465	2,68	1,80	405	2,33	1,68	309	1,80	1,44	210	1,19	1,19
	MIN	310	398	2,29	1,53	318	1,83	1,32	267	1,55	1,22	177	1,01	1,01
TL 2.4T	MAX	710	718	4,11	2,84	574	3,27	2,49	467	2,72	2,30	330	1,85	1,85
	MED	500	569	3,27	2,22	455	2,61	1,94	374	2,18	1,79	260	1,47	1,47
	MIN	320	398	2,29	1,53	318	1,83	1,32	267	1,55	1,22	177	1,01	1,01
TL 3.4T	MAX	880	791	4,51	3,14	656	3,72	2,88	512	2,98	2,56	366	2,04	2,04
	MED	610	632	3,61	2,47	520	2,96	2,23	413	2,40	2,00	288	1,61	1,61
	MIN	430	510	2,94	1,98	405	2,33	1,72	337	1,96	1,59	231	1,32	1,32
TL 4.4T	MAX	1140	1299	7,47	5,04	1090	6,26	4,50	864	5,02	4,04	586	3,33	3,33
	MED	820	1027	5,92	3,95	866	4,98	3,52	691	4,02	3,15	462	2,63	2,63
	MIN	630	842	4,86	3,21	713	4,11	2,87	572	3,33	2,56	374	2,14	2,14
TL 5.4T	MAX	1500	1588	9,11	6,23	1327	7,59	5,57	1046	6,08	5,02	726	4,10	4,10
	MED	970	1158	6,67	4,47	974	5,60	4,00	775	4,50	3,57	524	2,99	2,99
	MIN	710	920	5,31	3,52	778	4,48	3,15	623	3,62	2,81	411	2,35	2,35
TL 6.4T	MAX	1820	1836	10,50	7,26	1529	8,72	6,49	1199	6,97	5,98	849	4,77	4,77
	MED	1280	1423	8,18	5,55	1191	6,84	4,96	942	5,48	4,46	646	3,66	3,66
	MIN	710	920	5,31	3,52	778	4,48	3,15	623	3,62	2,81	411	2,35	2,35

Heating emission of 2 battery units (4 pipe installation)

Entering air temperature: +20°C

		WT: 45/40 °C			WT: 50/40 °C		WT: 60/50 °C		WT: 70/60 °C		WT: 80/70 °C	
Mod.	Speed	Qv	Qw	Ph	Qw	Ph	Qw	Ph	Qw	Ph	Qw	Ph
		m³/h	l/h	kW	l/h	kW	l/h	kW	l/h	kW	l/h	kW
TL 0.4T	MAX	610	256	1,49	134	1,56	197	2,29	261	3,03	325	3,78
	MED	420	215	1,25	113	1,31	166	1,93	219	2,54	272	3,17
	MIN	310	166	0,96	87	1,01	128	1,49	169	1,96	210	2,44
TL 1.4T	MAX	520	283	1,65	149	1,73	218	2,54	298	3,46	358	4,17
	MED	420	247	1,44	130	1,51	191	2,22	260	3,02	312	3,63
	MIN	310	196	1,14	103	1,20	151	1,76	209	2,43	247	2,87
TL 2.4T	MAX	710	351	2,04	184	2,14	270	3,14	378	4,40	444	5,17
	MED	500	277	1,61	146	1,69	214	2,48	298	3,46	350	4,07
	MIN	320	196	1,14	103	1,20	151	1,76	209	2,43	247	2,87
TL 3.4T	MAX	880	402	2,34	211	2,45	310	3,60	426	4,95	510	5,93
	MED	610	317	1,84	166	1,94	244	2,84	341	3,97	401	4,67
	MIN	430	247	1,44	130	1,51	191	2,22	267	3,10	312	3,63
TL 4.4T	MAX	1140	771	4,48	410	4,76	596	6,93	783	9,10	970	11,28
	MED	820	609	3,54	324	3,77	471	5,48	618	7,19	766	8,90
	MIN	630	501	2,91	267	3,11	388	4,51	508	5,91	629	7,31
TL 5.4T	MAX	1500	929	5,40	493	5,73	718	8,34	946	11,00	1170	13,60
	MED	970	686	3,99	365	4,25	531	6,17	697	8,10	864	10,04
	MIN	710	547	3,18	291	3,39	423	4,92	555	6,45	686	7,98
TL 6.4T	MAX	1820	1074	6,24	569	6,61	829	9,64	1092	12,70	1353	15,74
	MED	1280	845	4,91	449	5,22	653	7,60	858	9,98	1064	12,37
	MIN	710	547	3,18	291	3,39	423	4,92	555	6,45	686	7,98

Emission correction factors for different working conditions

Multiply the factors by the emission figures in the 7-12°C table above.

Note: the correction factors are indicative, as they are average values.

		TOTAL EMISSION			SENSIBLE EMISSION			
Water (°C)	Air (°C)	25-18	26-18.5	28-20	Air (°C)	25-18	26-18.5	28-20
7/12	K	0,82	0,89	1,11	K	0,90	0,94	1,06
10/15	K	0,56	0,63	0,82	K	0,72	0,78	0,90
14/18	K	0,35	0,41	0,52	K	0,50	0,58	0,72

LEGEND

- WT = Water temperature
- Pc = Cooling total emission
- Ps = Cooling sens. emission
- Ph = Emission
- Qw = Water flow
- Speed = Fan speed
- MAX = High speed
- MED = Medium speed
- MIN = Low speed
- Qv = Air flow

## Emission of 4 pipe units with enhanced cooling battery

### Cooling emission of 2 battery units (4 pipe installation)

Entering air temperature: +27°C d.b. – +19°C w.b.

Mod.	Speed	Qv m³/h	WT: 5/10 °C			WT: 7/12 °C			WT: 9/14 °C			WT: 12/17 °C		
			Qw l/h	Pc kW	Ps kW	Qw l/h	Pc kW	Ps kW	Qw l/h	Pc kW	Ps kW	Qw l/h	Pc kW	Ps kW
TL 2.6T	MAX	710	812	4,65	3,22	664	3,86	2,88	528	3,00	2,53	378	2,13	2,13
	MED	500	629	3,62	2,47	519	3,02	2,20	415	2,37	1,93	288	1,63	1,63
	MIN	320	425	2,45	1,64	355	2,07	1,47	287	1,65	1,29	192	1,10	1,10
TL 3.6T	MAX	880	940	5,37	3,77	764	4,44	3,37	606	3,43	2,96	442	2,48	2,48
	MED	610	729	4,18	2,87	597	3,47	2,56	477	2,71	2,25	337	1,90	1,90
	MIN	430	557	3,21	2,18	462	2,69	1,94	370	2,12	1,70	256	1,46	1,46
TL 5.6T	MAX	1500	1804	10,37	7,13	1488	8,65	6,37	1189	6,79	5,60	836	4,74	4,74
	MED	970	1291	7,44	5,02	1078	6,27	4,49	867	4,98	3,94	587	3,35	3,35
	MIN	710	1012	5,85	3,90	851	4,95	3,49	689	3,96	3,06	459	2,63	2,63
TL 6.6T	MAX	1820	2105	12,07	8,40	1725	10,03	7,51	1375	7,82	6,60	987	5,57	5,57
	MED	1280	1607	9,25	6,32	1332	7,75	5,64	1066	6,11	4,96	739	4,21	4,21
	MIN	710	1012	5,85	3,90	851	4,95	3,49	689	3,96	3,06	459	2,63	2,63

### Heating emission of 2 battery units (4 pipe installation)

Entering air temperature: +20°C

Mod.	Speed	Qv m³/h	WT: 45/40 °C			WT: 50/40 °C		WT: 60/50 °C		WT: 70/60 °C		WT: 80/70 °C	
			Qw l/h	Ph kW	Qw l/h	Ph kW	Qw l/h	Ph kW	Qw l/h	Ph kW	Qw l/h	Ph kW	
TL 2.6T	MAX	710	279	1,62	139	1,61	213	2,48	288	3,35	363	4,22	
	MED	500	226	1,32	113	1,32	173	2,01	233	2,71	294	3,42	
	MIN	320	165	0,96	83	0,97	127	1,47	170	1,98	214	2,49	
TL 3.6T	MAX	880	315	1,83	156	1,82	241	2,80	326	3,79	411	4,78	
	MED	610	255	1,48	127	1,48	195	2,27	263	3,06	332	3,86	
	MIN	430	205	1,19	103	1,20	157	1,83	212	2,46	266	3,10	
TL 5.6T	MAX	1500	720	4,18	493	4,33	554	6,44	736	8,56	919	10,69	
	MED	970	541	3,14	365	3,27	416	4,84	552	6,42	689	8,01	
	MIN	710	441	2,56	291	2,67	340	3,95	450	5,23	561	6,52	
TL 6.6T	MAX	1820	824	4,79	569	6,61	633	7,36	843	9,80	1053	12,24	
	MED	1280	651	3,79	449	5,22	501	5,83	666	7,74	831	9,66	
	MIN	710	441	2,56	291	3,39	340	3,95	450	5,23	561	6,52	

#### Emission correction factors for different working conditions

Multiply the factors by the emission figures in the 7-12°C table above.

Note: the correction factors are indicative, as they are average values.

Water (°C)	Air (°C)	TOTAL EMISSION			Air (°C)	SENSIBLE EMISSION		
		25 - 18	26 - 18.5	28 - 20		25 - 18	26 - 18.5	28 - 20
7/12	K	0,82	0,89	1,11	K	0,90	0,94	1,06
10/15	K	0,56	0,63	0,82	K	0,72	0,78	0,90
14/18	K	0,35	0,41	0,52	K	0,50	0,58	0,72

#### LEGEND

- WT = Water temperature
- Pc = Cooling total emission
- Ps = Cooling sens. emission
- Ph = Emission
- Qw = Water flow
- Speed = Fan speed
- MAX = High speed
- MED = Medium speed
- MIN = Low speed
- Qv = Air flow



## 2 pipe installation

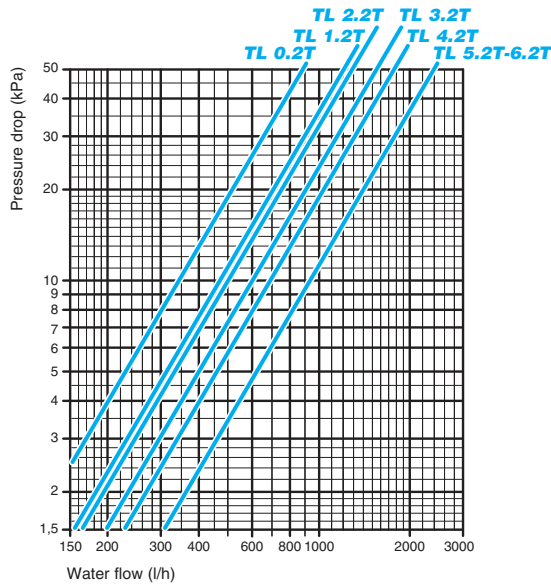

The water pressure drop figures refer to a mean water temperature of **10°C**; for different temperatures, multiply the pressure drop figures by the correction factors **K**.

°C	20	30	40	50	60	70	80
<b>K</b>	0,94	0,90	0,86	0,82	0,78	0,74	0,70

## 4 pipe installation

### Pressure drop for cooling battery

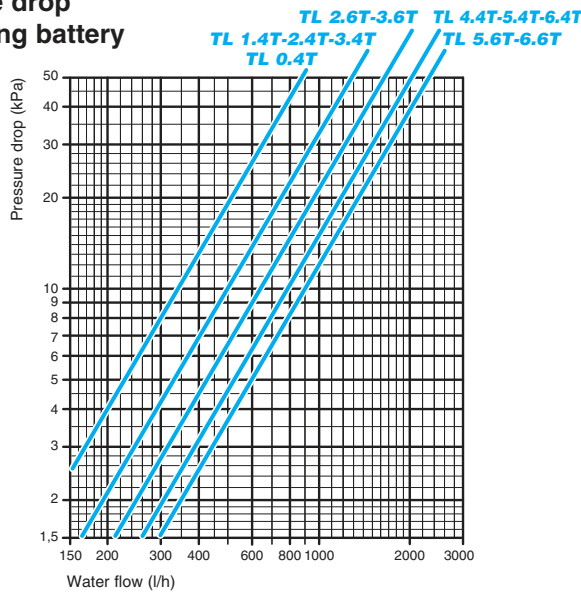

The water pressure drop figures refer to a mean water temperature of **10°C**; for different temperatures, multiply the pressure drop figures by the correction factors **K**.

°C	20	30	40	50	60	70	80
<b>K</b>	0,94	0,90	0,86	0,82	0,78	0,74	0,70

### Pressure drop for heating battery

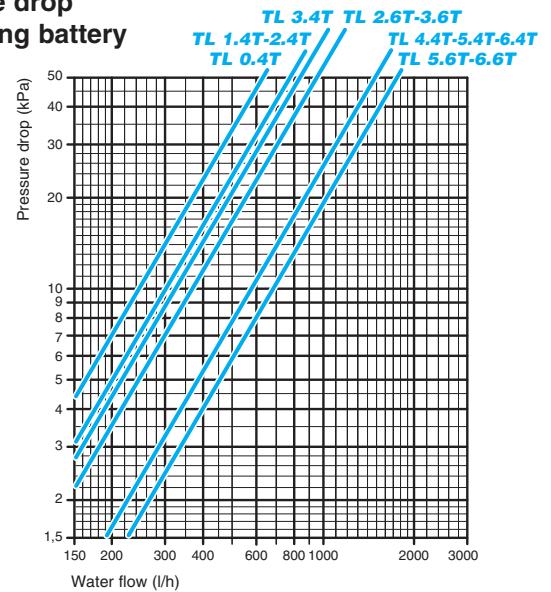

The water pressure drop figures refer to a mean water temperature of **60°C**; for different temperatures, multiply the pressure drop figures by the correction factors **K**.

°C	40	50	70	80
<b>K</b>	1,12	1,06	0,94	0,88

## Working conditions

<b>Water flow</b>	MAX. working pressure: 8 bars
<b>Air flow</b>	Suitable relative humidity: 15-75%
<b>Supply</b>	Single phase 230V / 50Hz
<b>Installation</b>	MAX. height: see table on page 12

MIN. entering water temperature: +5°C
MAX. entering water temperature: +80°C
MIN. entering air temperature: +6°C
MAX. entering air temperature: +40°C

## Dimensions and weights

### TL 0.2T-0.4T/TL 1.2T-1.4T/TL 2.2T-2.4T-2.6T/TL 3.2T-3.4T-3.6T (Version 600 x 600)

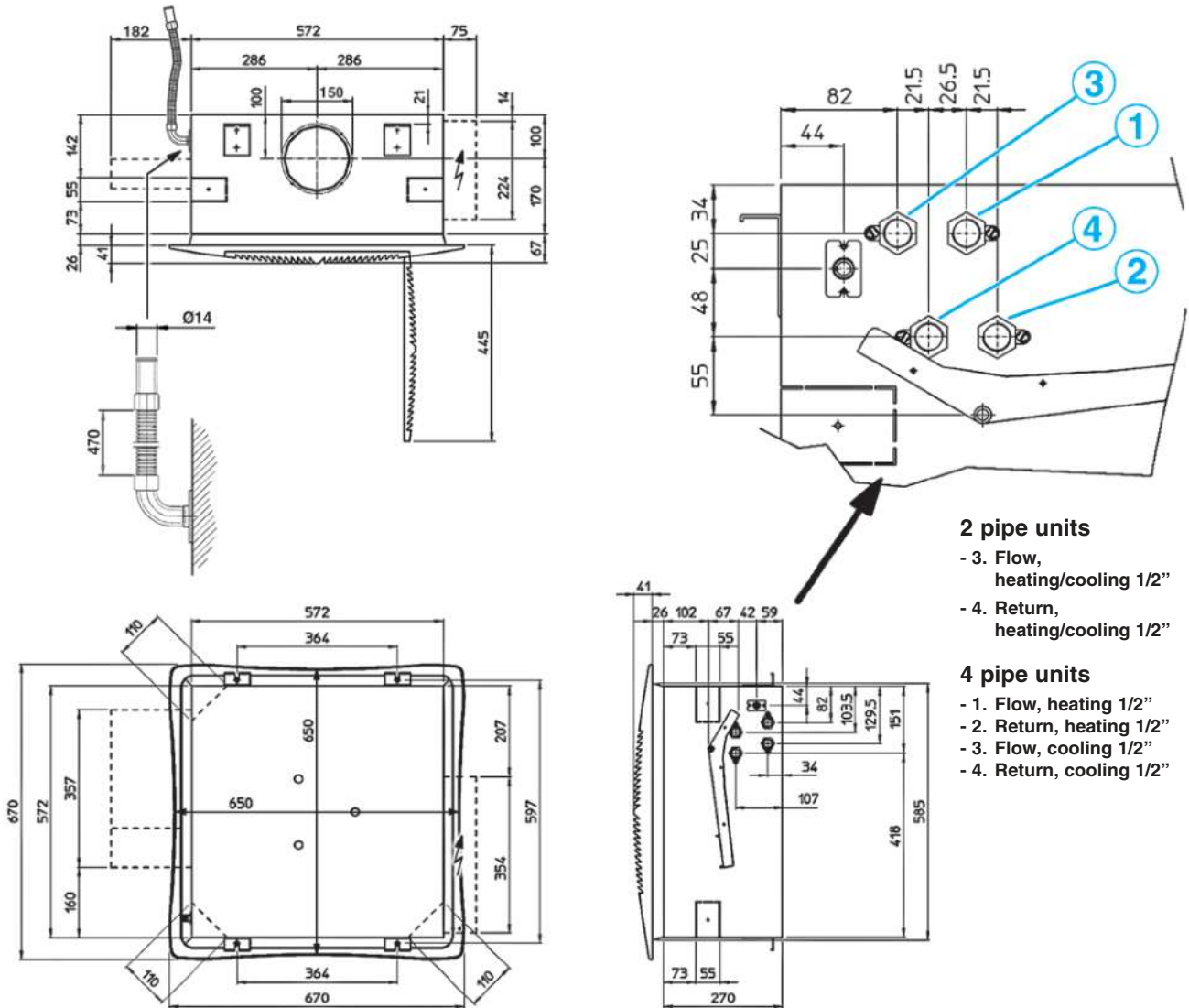

### MD-600/MD-800 METAL DIFFUSER

(RS receiver, Code 9066338, for MD-600/MD-800 metal diffuser for MB units)

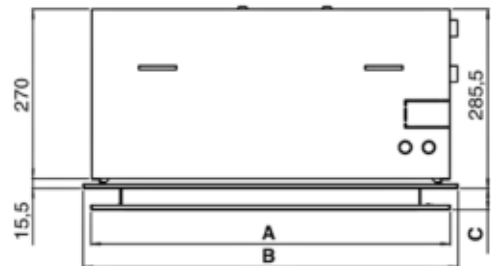
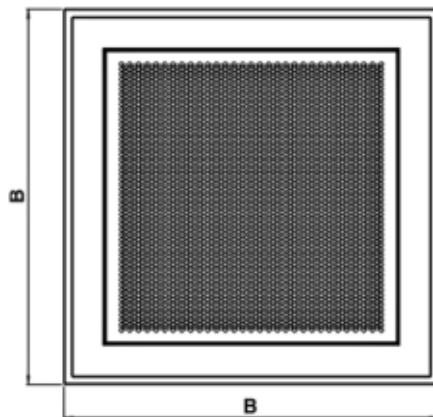

Size	A	B	C	Code
<b>MD-600</b>	574	599	34,5	9079420
<b>MD-800</b>	845	880	45,5	9079417

Model	UNIT		DIFFUSER		Packed unit Dimensions			
	Weights packed unit	Weights unpacked unit	Weights packed unit	Weights unpacked unit	A	B	C	D
	kg	kg	kg	kg	mm			
<b>TL 0.2T/1.2T</b>	28	22	6	3	790	350	750	150
<b>TL 0.4T/1.4T</b>	30	24						
<b>TL 2.2T/2.4T/2.6T</b>								
<b>TL 3.2T/3.4T/3.6T</b>								

## TL 4.2T-4.4T / TL 5.2T-5.4T-5.6T / TL 6.2T-6.4T-6.6T (Version 800 x 800)

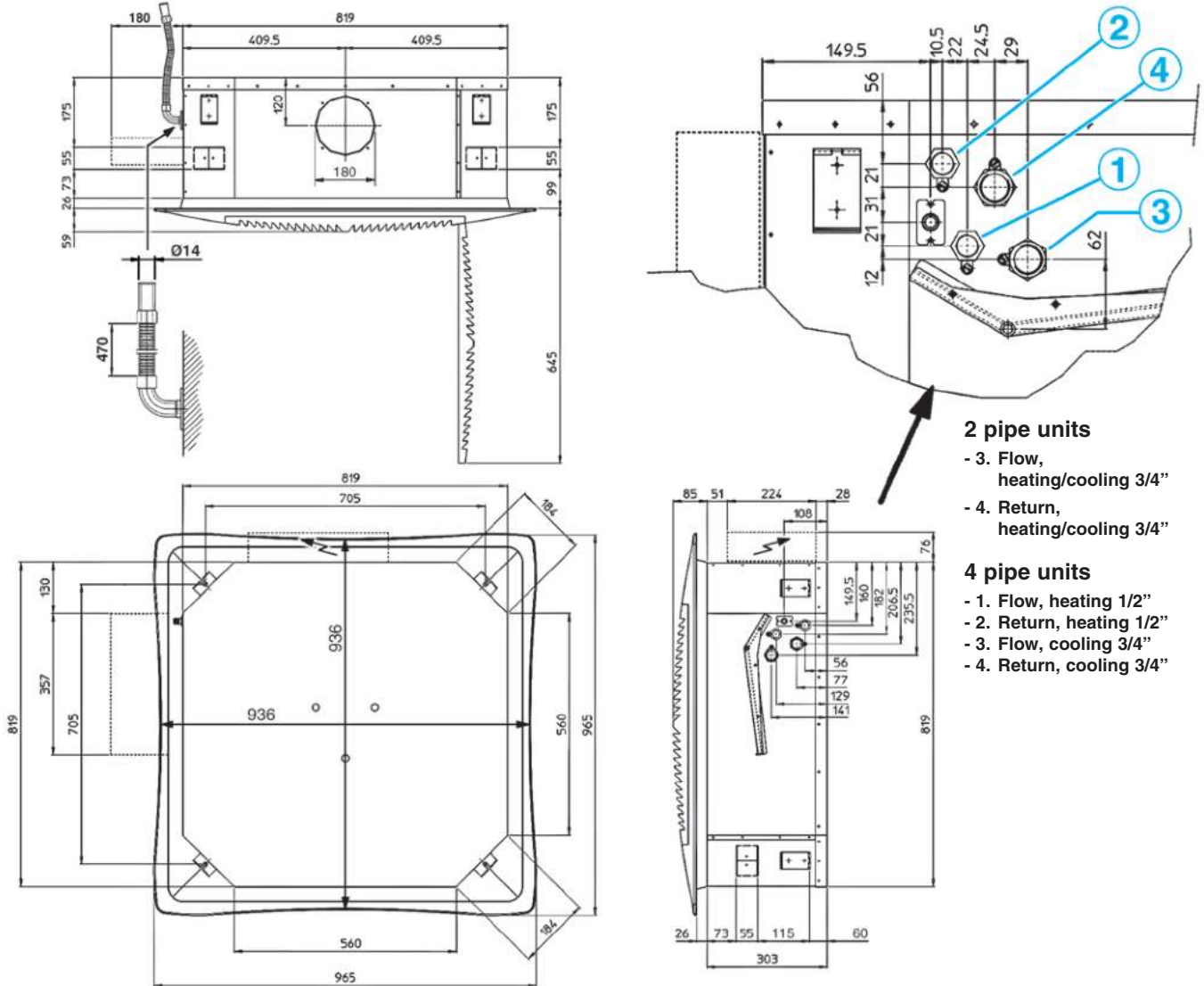

### PACKED UNIT

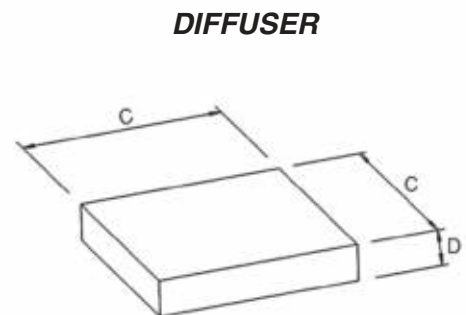
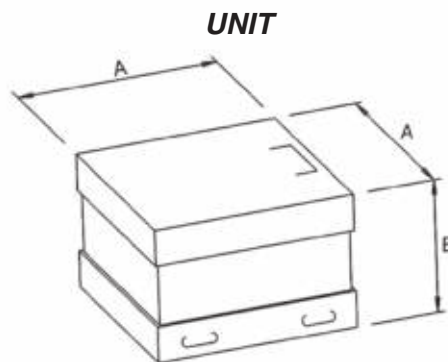

Model	UNIT		DIFFUSER		Packed unit Dimensions			
	Weights packed unit	Weights unpacked unit	Weights packed unit	Weights unpacked unit	A	B	C	D
					mm			
TL 4.2T	kg	kg	kg	kg	1050	400	1000	200
TL 4.4T	44	36	10	6				
TL 5.2T/5.4T/5.6T	47	39						
TL 6.2T/6.4T/6.6T								

## Air throw

The air throw indicated in the tables must only be considered the maximum value, as it may change significantly in relation to the dimensions of the room in which the appliance is installed and the positioning of the furniture in the room.

The useful throw **L** refers to the distance between the unit and the point where the air speed is 0.2 m/sec; if the louver has a gradient of 30° (recommended in cooling mode), the so-called “Coanda” effect will occur, illustrated in the first figure, while at a gradient of 45° (recommended in heating mode), there will be a downwards throw, as illustrated in the second figure.

### With adjustable air diffusion louvers at 30°

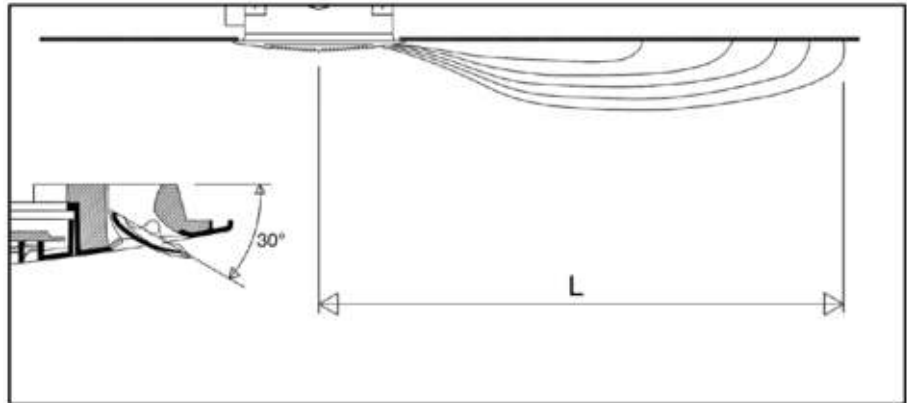

Model	<b>TL 0 - 1</b>			<b>TL 2</b>			<b>TL 3</b>			<b>TL 4</b>			<b>TL 5</b>			<b>TL 6</b>			
Speed		1	2	3	1	2	3	1	2	3	1	2	3	1	2	3	1	2	3
Air throw <b>L</b>	m	3,0	3,5	3,8	3,0	3,8	4,5	3,5	4,2	5,0	3,2	3,7	4,3	3,4	4,0	5,0	3,4	4,6	5,5

### With adjustable air diffusion louvers at 45°

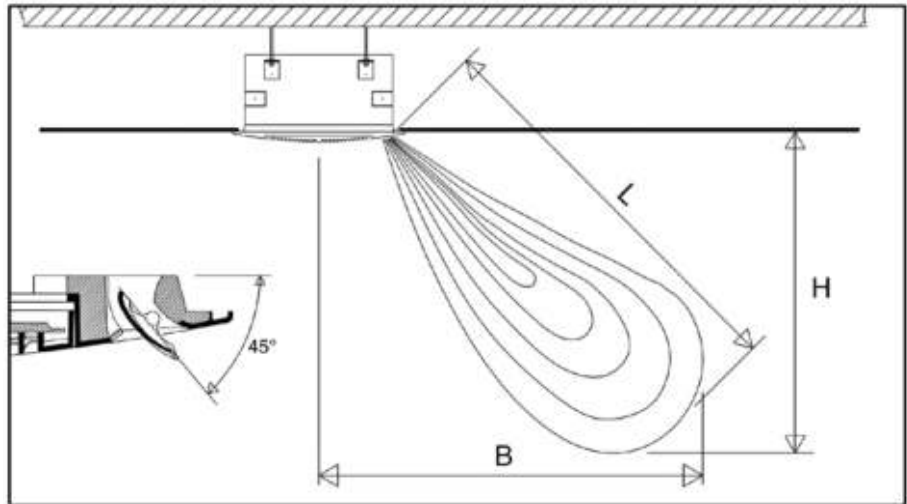

Model	<b>TL 0 - 1</b>			<b>TL 2</b>			<b>TL 3</b>			<b>TL 4</b>			<b>TL 5</b>			<b>TL 6</b>			
Speed		1	2	3	1	2	3	1	2	3	1	2	3	1	2	3	1	2	3
Air throw <b>L</b>	m	3,3	3,9	4,2	3,3	4,2	4,8	3,9	4,5	5,2	3,5	4,1	4,8	3,8	4,6	5,4	3,8	5,1	5,8
Height <b>H</b>	m	2,2	2,6	2,8	2,2	2,8	3,2	2,6	3,0	3,4	2,2	2,6	3,0	2,4	2,8	3,4	2,4	3,1	3,6
Distance <b>B</b>	m	2,5	2,9	3,1	2,5	3,1	3,6	2,9	3,4	3,9	2,7	3,2	3,8	3,0	3,6	4,2	3,0	4,0	4,6

#### NOTE:

On heating it must be paid attention to rooms where the floor temperature is particularly low (for example less than 5°C).

In this situation the floor can cool the lower layer of air to a level that stop the uniform diffusion of the hot air coming from the unit, decreasing the throw figures shown in the table.

## Fresh air supply - Fresh air connection

Fresh air connection for TL 0-1-2-3 models (not suitable for MCT models with outer casing).

The cassette is fitted with inlets for fresh air to be mixed with return air inside the unit (Fig. 3).

The fresh air flow is limited to 20% of the total fan coil air flow at medium speed and 100 m<sup>3</sup>/h for each treated air inlet.

The units feature fresh air inlets on three corners (no inlets on the fourth corner because of the condensate pump inside the unit).

The fresh air inlets are designed for the insertion of standard 110 x 55 mm rectangular ducts.

The air duct is connected quickly and easily. After removing the blank and the insulation inside the unit, the mounting plate is rolled back and the air duct with its V-shaped section must be pushed into the unit (see Figures below). The duct is then fixed to the mounting plate.

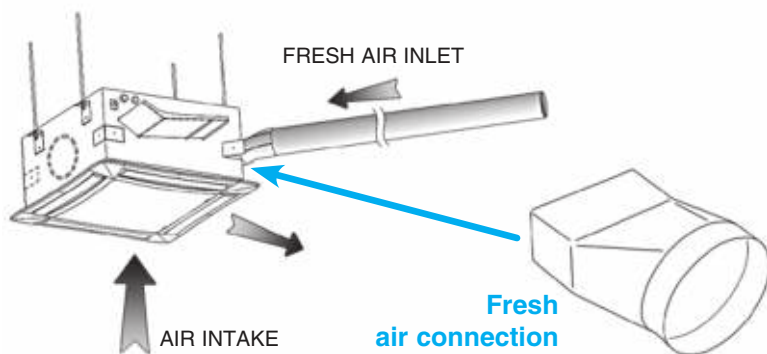

**Note:** the fresh air must be filtered.

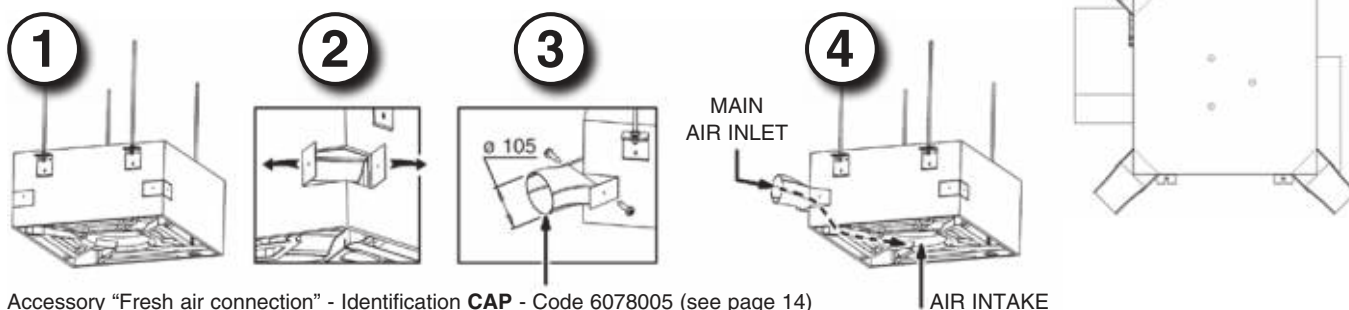

Accessory "Fresh air connection" - Identification CAP - Code 6078005 (see page 14)

## Air distribution - Air distribution connection

Two air outlets are provided on the side of the unit for connection to separate supply air outlets.

They can be used to supply air from the fan coil unit to distant areas of a room or even to a different room.

The total air flow does not change.

The air flow at high speed depending on the air duct pressure drop is shown in the tables below.

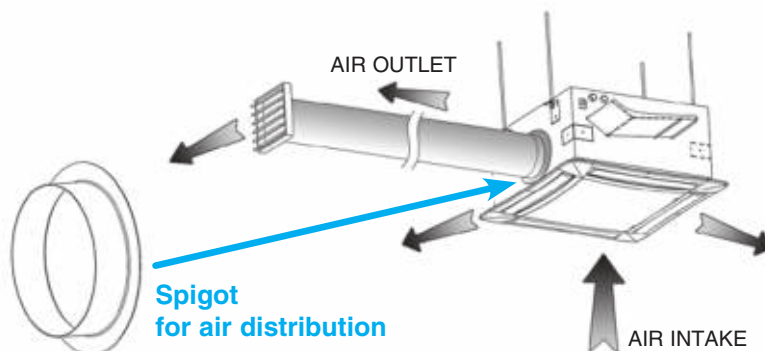

**Note:** all air ducts must be insulated in order to avoid condensation.

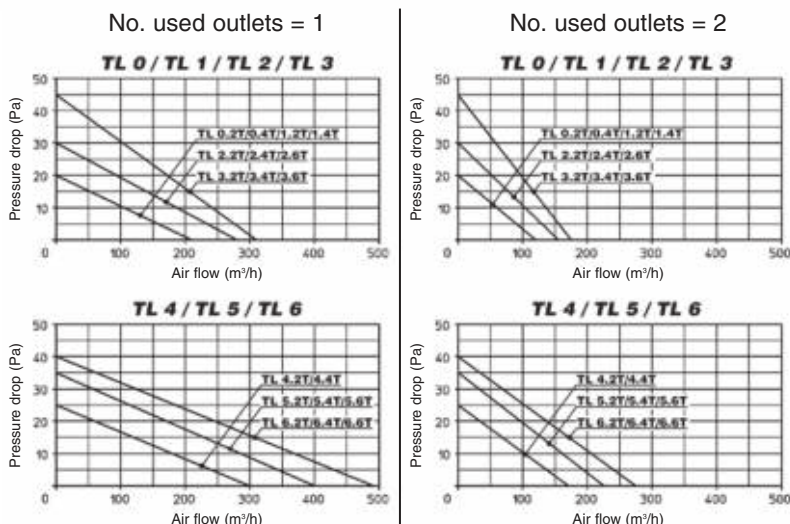
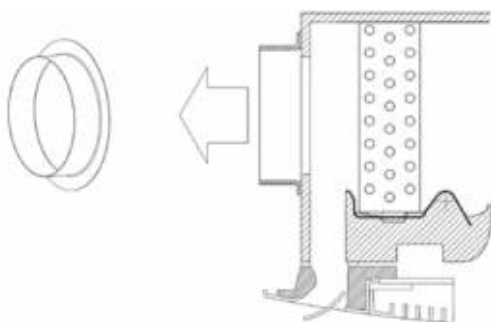

## Accessories

### Fresh air connection

Only for TL 0-1-2-3 models  
(not suitable for MCT models with outer casing).

See page 13.

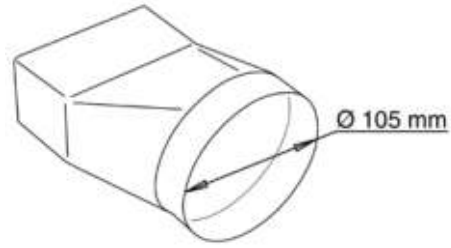

IDENTIFICATION	CODE
CAP	6078005

### Air distribution connection

See page 13.

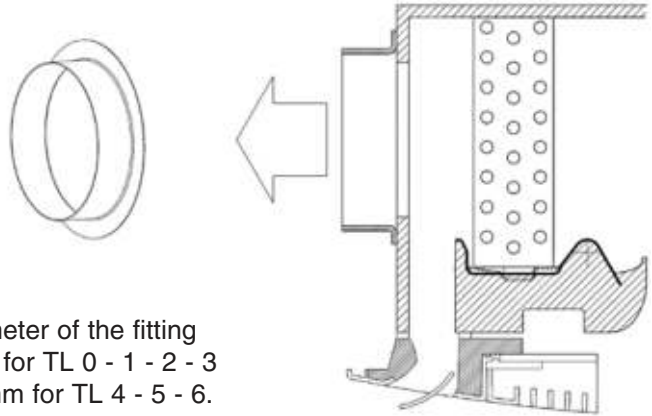

The diameter of the fitting is 150 mm for TL 0 - 1 - 2 - 3 and 180 mm for TL 4 - 5 - 6.

IDENTIFICATION	CODE
CDA 600	9079232
CDA 800	9079233

### Fresh air kit

This is used to introduce fresh air into the environment directly through the diffuser. The kit includes a flow separator to be fitted inside the cassette, and a circular fitting for connection to the flexible system ducting. The flow of air is sent directly to just one of the outlet louvers, without passing through the coil. The air flow of fresh air introduced into the environment depend on the inlet static pressure.

MODEL	TL 0-1-2-3	TL 4-5-6
IDENTIFICATION	PRT 600	PRT 800
CODE	9079230	9079231

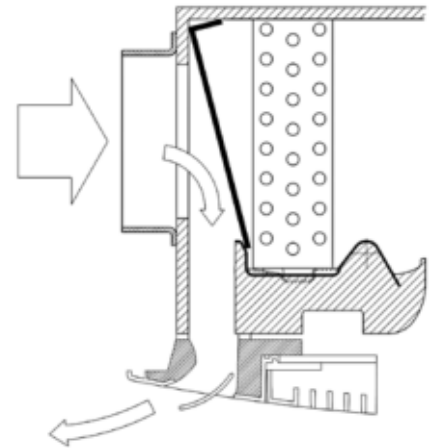

The diameter of the fitting is 150 mm for TL 0 - 1 - 2 - 3 and 180 mm for TL 4 - 5 - 6.

### Correlation between flow-rate / static pressure

TL 0-1-2-3		TL 4-5-6	
m <sup>3</sup> /h	Pa	m <sup>3</sup> /h	Pa
80	3	160	3
120	8	200	8
160	15	300	15
200	25	400	25
240	36	500	36

### Units with remote electric board

On request the TopLine cassettes are available with electric control panel reachable from below and with the electric board that can be placed in a remote position. In this case the units are supplied with an electronic connecting control panel, fitted to the bottom side on the 4 smallest sizes and to the lateral side on the 3 biggest sizes.

The electronic control panel is connected to the fan motor, to the condensate pump and to the condensate level control.

A 6 m wire is also supplied with integral plug-in connections to connect the unit with the remote electric board that can be installed in a suitable and comfortable position, where the power and system connections can be made easily.

This feature is not available for units with electric heater or infrared remote control.

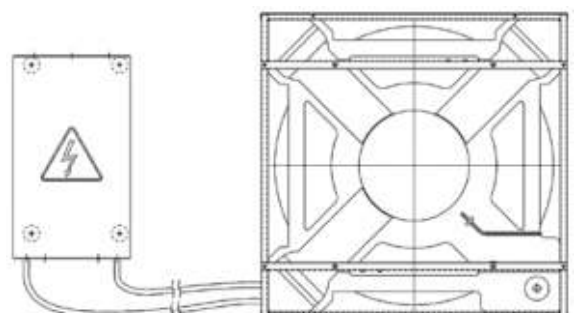

ON-OFF valves with thermoelectric actuator

VALVE WITH MICROMETRIC LOCKSHIELD VALVE

**3 ways**



TL 0.2-0.4  
TL 1.2-1.4  
TL 2.2-2.4-2.6  
TL 3.2-3.4-3.6

TL 4.2-4.4  
TL 5.2-5.4-5.6  
TL 6.2-6.4-6.6

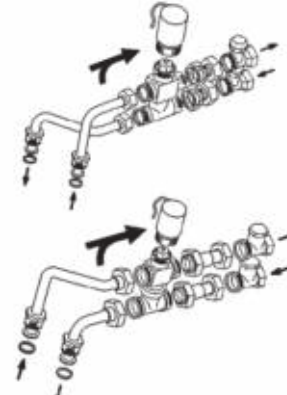

**2 ways**



TL 0.2-0.4  
TL 1.2-1.4  
TL 2.2-2.4-2.6  
TL 3.2-3.4-3.6

TL 4.2-4.4  
TL 5.2-5.4-5.6  
TL 6.2-6.4-6.6

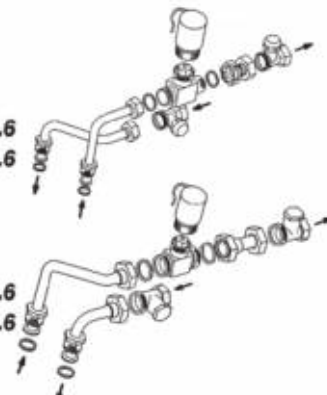

VALVE WITH SIMPLIFIED KIT

**3 ways**



TL 0.2-0.4  
TL 1.2-1.4  
TL 2.2-2.4-2.6  
TL 3.2-3.4-3.6

TL 0.2-0.4  
TL 1.2-1.4  
TL 2.2-2.4-2.6  
TL 3.2-3.4-3.6

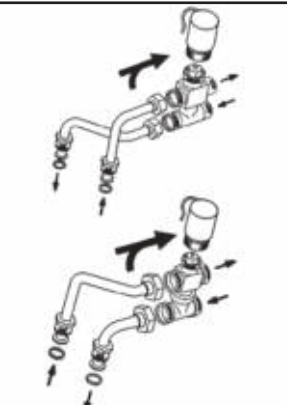

**2 ways**



TL 0.2-0.4  
TL 1.2-1.4  
TL 2.2-2.4-2.6  
TL 3.2-3.4-3.6

TL 0.2-0.4  
TL 1.2-1.4  
TL 2.2-2.4-2.6  
TL 3.2-3.4-3.6

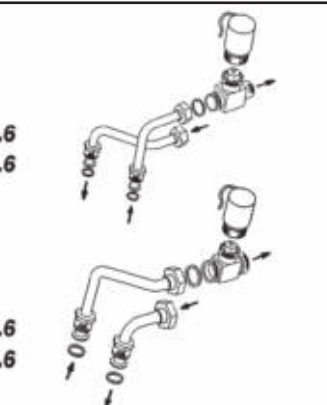

Technical data:

Rated pressure:	16 bar
Max. ambient temperature:	50 °C
Max. water flow temperature:	110 °C
Power:	230 V - 50/60 Hz
Rating:	3 VA
Protection:	IP 43
Travel time:	approx. 3 min.
Max. glycol content of water:	50%

Valves characteristics

Battery type	Model	2 way valves			3 way valves		
		Kvs m³/h	Δp <sub>max</sub> kPa *	Valve ** connection	Kvs m³/h	Δp <sub>max</sub> kPa *	Valve ** connection
Main	0.2/1.2/2.2/3.2	2,8	50	3/4"	2,5	50	3/4"
	0.4/1.4/2.4/2.6/3.4/3.6						
	4.2/5.2/6.2	5,2	60	1"			
Auxiliary	0.4/1.4/2.4/2.6/3.4/3.6	2,8	50	3/4"	2,5	50	3/4"
	4.4/5.4/5.6/6.4/6.6						

\* maximum pressure difference for valve to close    \*\* external thread, flat seal  
 Note: 3 way valves with simplified kit and 1" connection have conical seal.

Valves pressure drop

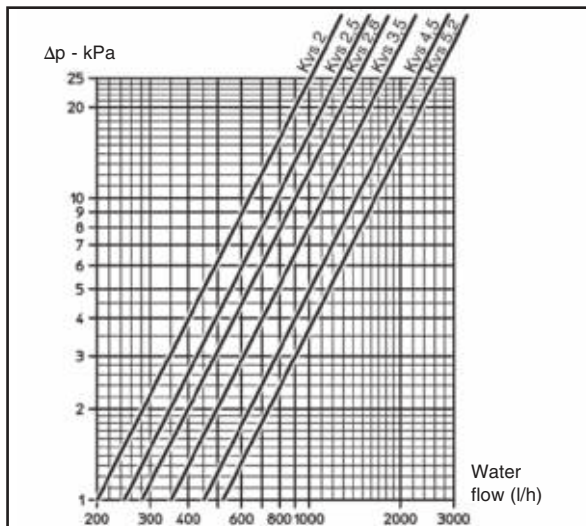

Valve set, 2 or 3 ways, ON-OFF, with thermoelectric actuator. The set includes connection pipes.

**Note:** The main battery lockshield valve connection is 1/2" female (Kvs 2) for TL0 - TL1 - TL2 - TL3 sizes and 3/4" female (Kvs 3,5) for TL4 - TL5 - TL6 sizes, the auxiliary battery valve connection is 1/2" female (Kvs 2).

**Note:** The maximum pressure drop across the fully open valve should not exceed 25 kPa for cooling operation and 15 kPa for heating operation.

## Accessories

### Balancing valves independent from the system pressure

- The balancing valve and a combined 2 way valve allow the regulation of the water flow value autonomously, regardless of the system pressure, and the control of the flow by using an ON/OFF electro-thermal actuator.
- The balancing valve allows you to balance the hydraulic system by supplying the required water flow, for each fan- coil, and to maintain it even under partial load conditions.
- A graduated ring nut placed under the valve allows you to set the flow rate value and also allows direct reading of the set value.



### Valve operation logic

- “p1” is the valve inlet pressure.
- “p3” is the outlet pressure.
- “p2” is the diaphragm activation pressure, which allows differential pressure “p2” – “p3” to be maintained at a constant value, in order to guarantee the water to flow at the set value.

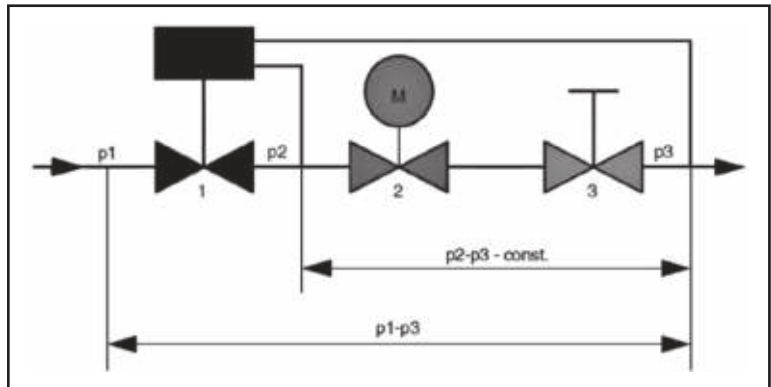

The minimum differential pressure “p1” – “p3”, required to guarantee the correct value of the set water flow rate, is indicated in the diagrams on page 17. This is an essential factor to size the system pressure drop and pump pressure head. The flow rate is kept at a constant value only if the valve pressure drop is higher than the indicated value.

### Minimum operating differential pressure

The minimum differential pressure and the balancing valve pressure drop must be considered to size the system pumps.

Flow rate is constant if the pressure drop is higher than that indicated in the diagrams on page 17.

The following diagram shows an example of the flow rate trend according to the pressure drop and calibration required.

#### Example DN 15 Model

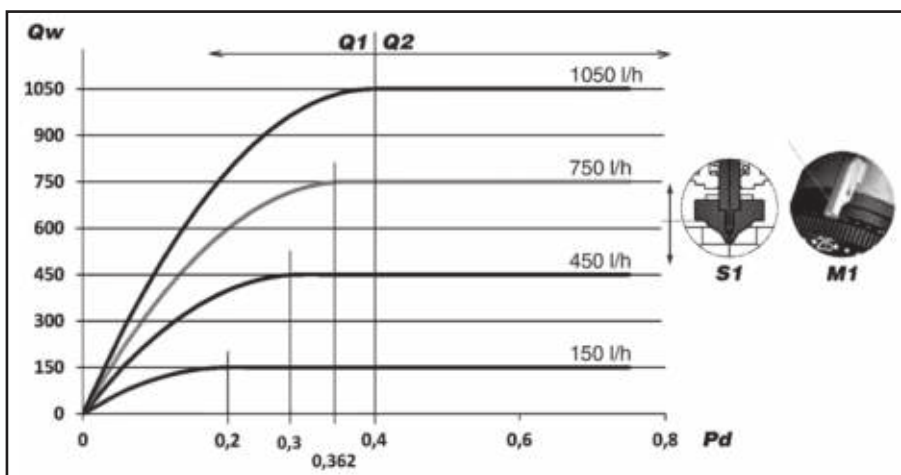

#### LEGEND:

**Qw** = Water flow rate (l/h)

**Pd** = Min. differential pressure  
“p1” – “p3” (bar)

**Q1** = Area with inconstant water flow

**Q2** = Area with constant water flow

**S1** = Position of the adjustment valve  
plunger

**M1** = Position of the knob



The valve upstream-downstream minimum differential pressure (“p1” – “p3”), which depends on the valve calibration value, must be exceeded to access the constant flow rate field.

**DN 15 Model**

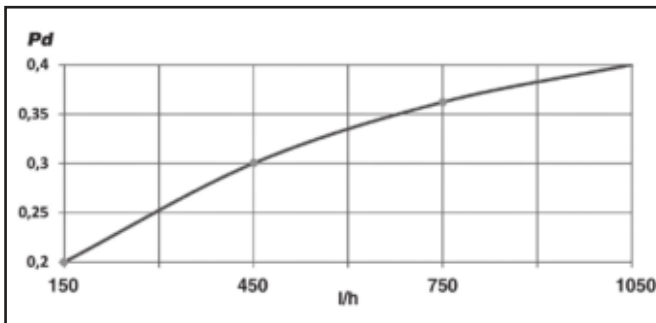

**DN 20 Model**

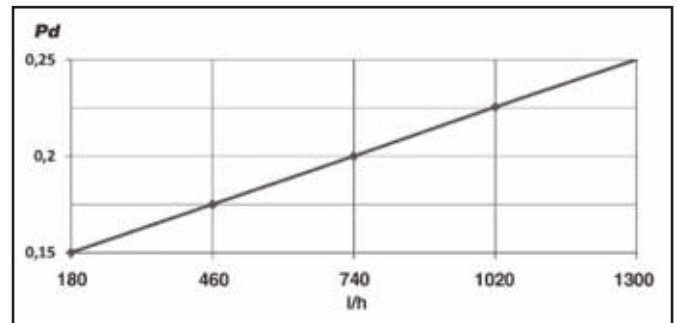

### LEGEND:

**Pd** = Min. differential pressure “p1” – “p3” (bar)

E.g., when sizing the system pump, in which the **DN 15** valves will be installed and in which 450 l/h are constantly required for each device, consider a useful pressure of 0.3 bar (to compensate the pressure drop of the valve) for each balancing valve. Therefore, the pressure drop values produced by the system balancing valves must be summed and the pump must be sized to produce a pressure equal to or greater than the value obtained previously.

## Benefits

- Reduced dimensions.
- Easy installation on 2 or 4 pipe devices.
- Pre-regulation of the nominal value set even with installed actuator.
- Easy display of the nominal value set. Nominal values are indicated in 10 l/h without any conversion.
- Guarantee of constant flow rate set even with partial loads.
- Pre-regulation can be blocked and leaded with the locking ring.

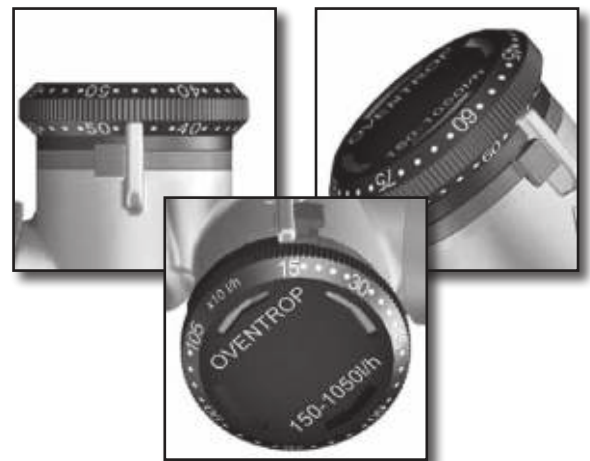

## Technical features

DN MODEL	FLOW RATE RANGE (l/h)	Kvs
<b>DN 15</b>	150 – 1050	1,8
<b>DN 20</b>	180 – 1300	2,5

## Operation limits of the balancing valves

- Maximum operating temperature 120°C
- Maximum operating pressure 16 bar
- Maximum % of water/glycol mixture 50%
- Minimum operating temperature -10°C
- Maximum differential pressure 4 bar

**Balancing valves for main coil**

2 way valve for main coil and assembly kit.

The valve is supplied equipped with 230 Volt electro-thermal actuator for the ON/OFF control.

**TL 0 - 1 - 2 - 3**

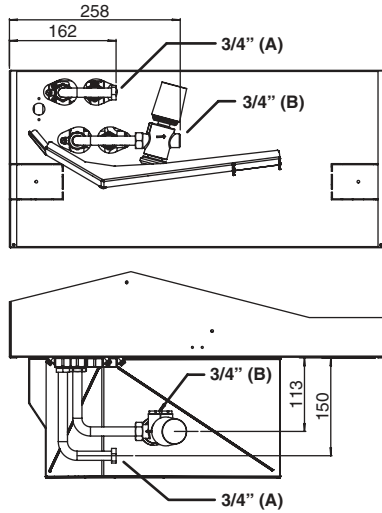

**TL 4**

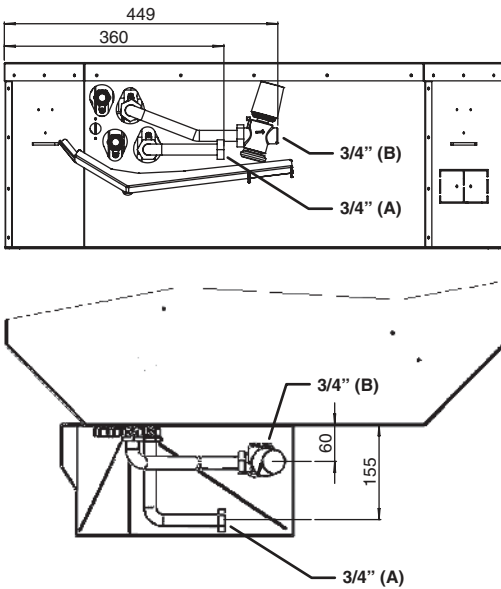

**TL 5 - 6**

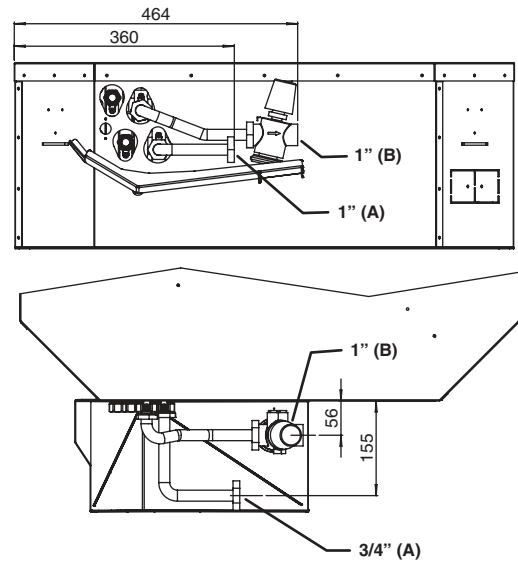

**LEGEND**

A = Water inlet - Female connection  
 B = Water outlet - Male connection

MODEL	VALVE			FITTED		NOT FITTED	
	DN	Ø	Flow Rate Range (l/h)	CODE	IDENTIFICATION	CODE	IDENTIFICATION
<b>0 - 1 - 2 - 3</b>	15	3/4"	150 - 1050	9079771	V2OVSK6BPM 150-1050	9079761	V2OVSK6BPS 150-1050
<b>4</b>	15	3/4"	150 - 1050	9079791	V2OVSK8BPM 150-1050	9079781	V2OVSK8BPS 150-1050
<b>5 - 6</b>	20	1"	180 - 1300	9079792	V2OVSK8BPM 180-1300	9079782	V2OVSK8BPS 180-1300

### Balancing valves for main and additional coil

2 way valve for additional coil and assembly kit.  
The valve is supplied equipped with 230 Volt electro-thermal actuator for the ON/OFF control.

#### TL 0 - 1 - 2 - 3

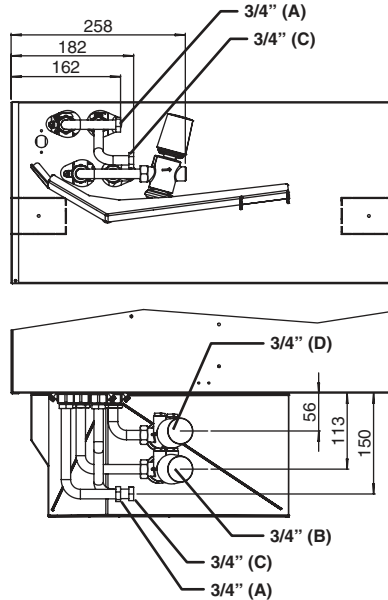

#### TL 4

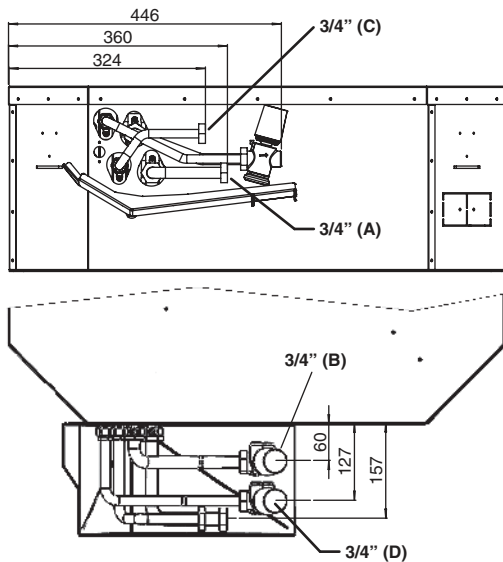

#### TL 5 - 6

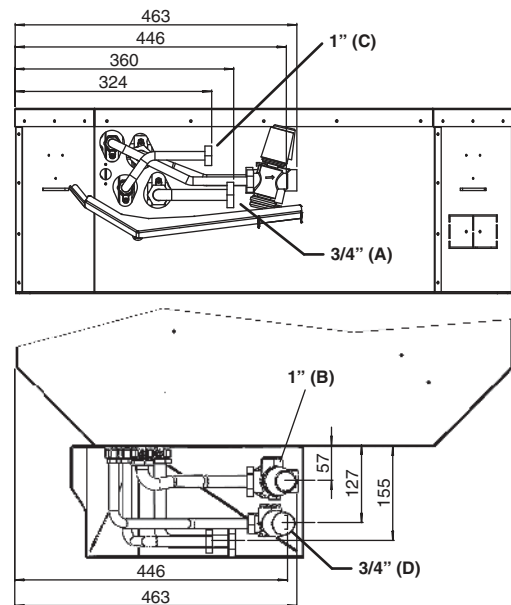

**LEGEND**

A = Water inlet (main coil) - Female connection  
B = Water outlet (main coil) - Male connection

C = Water inlet (additional coil) - Female connection  
D = Water outlet (additional coil) - Male connection

COIL	MODEL	VALVE			FITTED		NOT FITTED	
		DN	Ø	Flow Rate Range (l/h)	CODE	IDENTIFICATION	CODE	IDENTIFICATION
MAIN	0 - 1 - 2 - 3	15	3/4"	150 - 1050	9079771	V2OVSK6BPM 150-1050	9079761	V2OVSK6BPS 150-1050
	4	15	3/4"	150 - 1050	9079791	V2OVSK8BPM 150-1050	9079781	V2OVSK8BPS 150-1050
	5 - 6	20	1"	180 - 1300	9079792	V2OVSK8BPM 180-1300	9079782	V2OVSK8BPS 180-1300
ADDITIONAL	0 - 1 - 2 - 3	15	3/4"	150 - 1050	9079773	V2OVSK6BAM 150-1050	9079763	V2OVSK6BAS 150-1050
	4 - 5 - 6	15	3/4"	150 - 1050	9079793	V2OVSK8BAM 150-1050	9079783	V2OVSK8BAS 150-1050

## Electrostatic filter

### Introduction

**Cassette TopLine** can be equipped with the innovative plate type electrostatic filter, combining air treatment and purifying in a single product.

The electronic filter is patented and certified according to Standard UNI 11254.

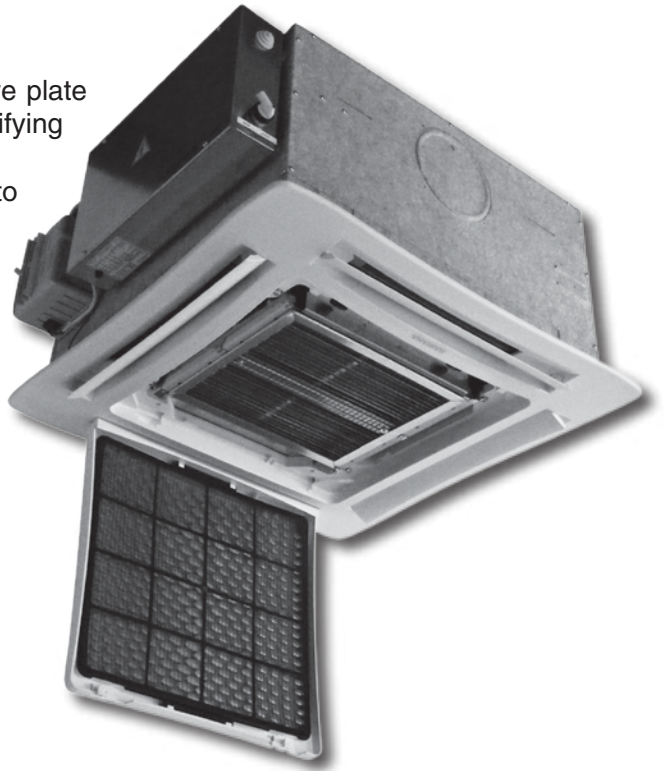
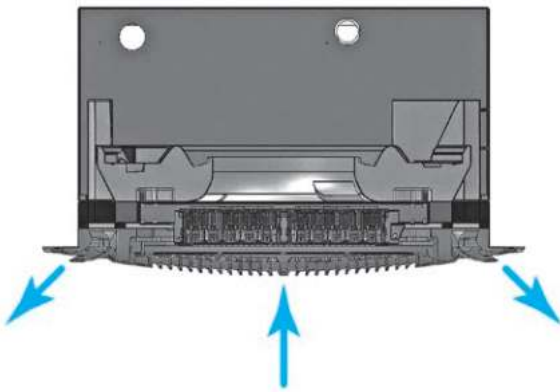

### Dimensions

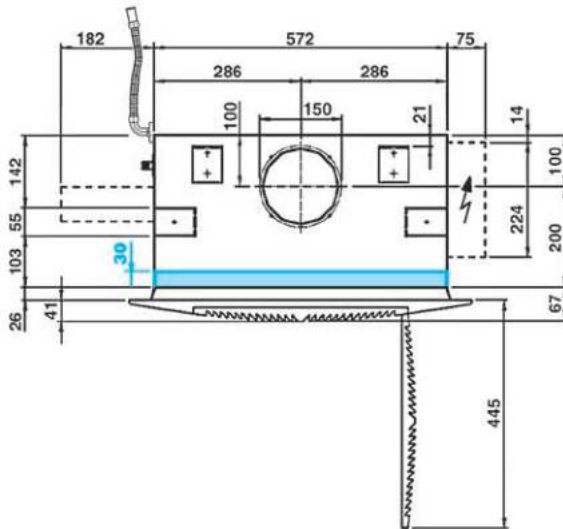

**TL 0 / 1 / 2 / 3**  
(Model 600 x 600)

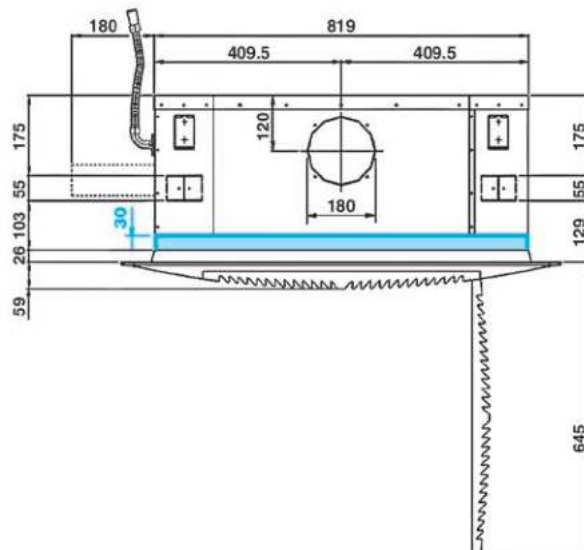

**TL 4 / 5 / 6**  
(Model 800 x 800)

## Electrostatic filter

### Operating principle of the electrostatic filter

When the polluted air goes through the mechanical pre-filter the particles  $\geq 50 \mu$  are eliminated (powder, insects, etc).

Then the smallest particles ( $50 \div 0.01 \mu\text{m}$ ) are exposed to an intensive ionizing field and are polarized (*Phase 1*).

The charged particles passing through the second filter section, are pushed back by the anode and attracted to the collection surfaces by a strong, induced magnetic field (*Phase 2*).

The air which leaves the unit is free from polluting particles.

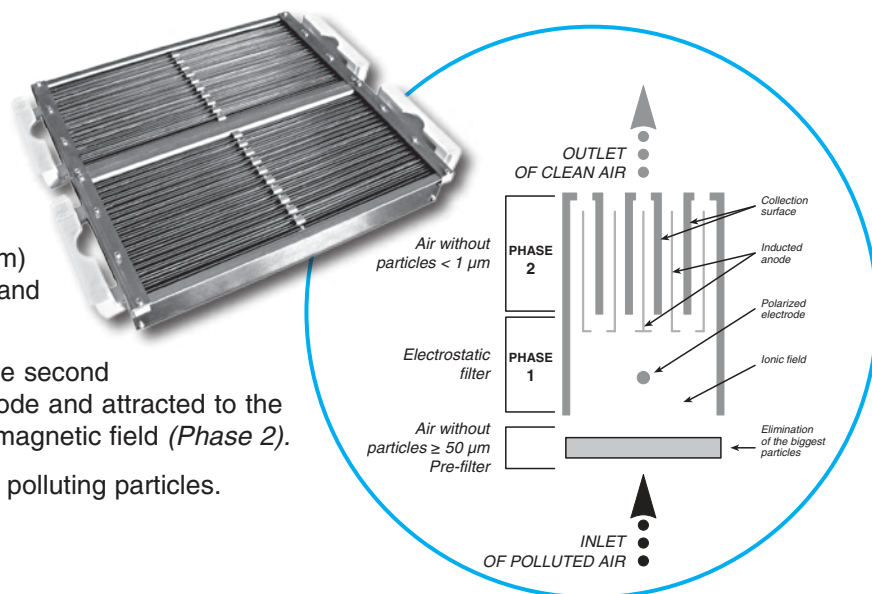

## Indoor air quality (IAQ)

The expression Indoor Air Quality (IAQ) covers all the procedures and methodologies used to **improve the quality of the air we breathe** in the places where we live and work, from all points of view, from temperature to cleanliness, to relative humidity, etc. (EN 15251 and EN 13779). Thanks to its new patented electronic filter, the **electrostatic filter totally eliminates the pollutants present in the air**, including tobacco smoke, dust (PM10, PM2.5), fibres, microbiological substances such as bacteria, fungi, etc., which are harmful to human health (source: OMS 2009). Purifying the air means not only greater well-being, but also energy saving, as the fresh air changes that are required to restore ideal climatic conditions and that entail greater consumption, are significantly reduced (it is sufficient to enter the quantity of air required to restore the optimum level of CO<sub>2</sub> - source: EN 1379:2008). Moreover, according to the UNI 10339rev, air recirculated by the electrostatic filter appliance can be considered as fresh air, to be added to the minimum requirements (0,5 ls/m<sup>2</sup>). Purifying the air with the electrostatic filter appliance also **entails no reduction of living room space**, as the dimensions of the fan convector are practically unchanged (just 3 cm higher). The positioning of the electronic filter allows **simple and effective maintenance** and, as it is easy to wash, **its working life is practically unlimited**. The modularity of the filter components and their ease of mounting make the system extremely competitive in terms of cost compared with other types of filters present on the market. In spring and autumn, if air conditioning/heating is not required, the appliance acts simply as an **air purifier**.

## Standards and legislation

### THE AMBIENT CONDITION IS ACCEPTABLE WHEN:

- **Microclimatic parameters are normal**
- **80% of people are satisfied by the quality of air**
- **Specific internal contaminants are not in harmful concentrations**

*“Guidelines for the protection and promotion of health in confined areas O.G.  
No. 276 dated 27 Nov 01 ordinary supplement no. 252”*

The method for obtaining the air quality required in confined areas and thus succeeding in ensuring that the contaminants present are in concentrations less than those considered dangerous to health are:

**Prescriptive approach:** ventilation of the internal area using only properly filtered fresh air, in the quantity and quality needed to dilute the internal contaminants in order to reach the required maximum acceptable concentration values (see WHO limits).

**Performance approach:** ventilation with fresh air and recirculated air from the same area, both properly filtered, in the quantity and quality needed to dilute the internal contaminants in order to reach the required maximum acceptable concentration values (see WHO limits).

## Electrostatic filter

The quantity and quality of recirculated air and outdoor air to be added is better specified in the prescriptive and performance approach in Standards UNI EN 13779:2008 and soon to be released UNI 10339rev according to the following simplified tables.

PRESCRIPTIVE METHOD	<b>UNI EN 13779:2008</b>			
	CATEGORY	UNIT	RATE OF FRESH AIR	
			TYPICAL RANGE	DEFAULT VALUE
	IDA 1	l.s. person	> 15	20
	IDA 2	l.s. person	10 – 15	12,5
IDA 3	l.s. person	6 – 10	8	
IDA 4	l.s. person	< 6	5	
<b>UNI EN 10339REV</b>				
CATEGORY	RATE OF FRESH AIR			
High	(l.s. per person) + (l.s. per m <sup>2</sup> )		Total fresh air volume varies based on the intended use of the confined area	
Medium	(l.s. per person) + (l.s. per m <sup>2</sup> )			
Low	(l.s. per person) + (l.s. per m <sup>2</sup> )			
not classified	not classified			

PERFORMANCE METHOD	<b>UNI EN 13779:2008</b>		
	<b>IDENTIFICATION AND QUANTIFICATION OF THE REFERENCE POLLUTANT (PM OR GAS)</b>		
	Concentration Limit	Minimum fresh air l.s. person	Quantity of recirculated air provided that it is filtered like fresh air
	WHO publicized values and legislative acts expressed in µg/m <sup>3</sup> , PPM, etc.	5 - 6	The volume of air to be considered is based on the internal production and the imposed concentration limits in the confined area
	<b>UNI EN 10339REV</b>		
<b>IDENTIFICATION AND QUANTIFICATION OF THE REFERENCE POLLUTANT (PM OR GAS)</b>			
Concentration Limit	Minimum fresh air l.s. person	Quantity of recirculated air provided that it is filtered like fresh air	
WHO publicized values and legislative acts expressed in µg/m <sup>3</sup> , PPM, etc.	The minimum volume of air input varies based on the intended use of the confined area	The volume of air to be considered is based on the internal production and the imposed concentration limits in the confined area	

## Fresh air flow rates according to the performance approach

### *UNI EN 13779:2008 and UNI 10339rev Standards*

The example reproduced at the bottom of the page shows how, with adequate air filtering, it is possible to decrease considerably the quantity of fresh air to be brought into the environment (up to 3-4 times less); the thermal energy dissipated due to ventilation is in fact in direct proportion to the number of air changes, as indicated in the following equation:

$$Q_v = \Delta T \cdot \frac{R}{3600} \cdot D \cdot C \cdot Vol.$$

- Q<sub>v</sub>** = Thermal energy lost for ventilation - Watt  
**ΔT** = Indoor-Outdoor difference (T) - °C  
**R** = A.C.H.  
**D** = Air density - Kg/m<sup>3</sup>  
**C** = Specific air heat - J/Kg-°C  
**Vol** = Room size - m<sup>3</sup>

## Electrostatic filter

### Construction features

The electrostatic filtering system consists of two parts: the first is a **plate type electronic active filter** and is fitted in the return air section of the cassette, while the second is an **electronic control and regulation board**, fixed on the structure.

All electrical connections are made during production. The installation of the TopLine cassette fan coil unit incorporating the electronic filter is therefore similar to that of a normal unit: the only difference is the installation height, for which the filter dimensions must be taken into account.

Electrostatic filters are not suitable for ECM and electric heater versions.

#### Active plate type electronic filter

The filtering element consists of two sections: the first consists of electrodes and insulating elements, forming a self-supporting ionising frame, while the second consists of special light aluminium fins (collector).

The two sections are installed above the return air grille to make the extraction and maintenance of the filter easier.

Accessibility to sections to be cleaned is ensured by easy-open plastic closures.

The collector can be cleaned by washing with water and ordinary detergents or steam jets (please consult the maintenance manual for further details).

#### Electronic board

Controls and regulates all functions of the electrostatic filter.

It is appropriately protected against any operating defects of the electrostatic filter. It supplies a constant voltage to the electrodes when the mains supply voltage varies ( $\pm 15\%$ ).

The supply transformer is constructed with its primary and secondary coils physically separated and wound onto separate cores.

The energy consumption of the filter group is 25 W (to which the electrical consumption of the Cassette must be added).

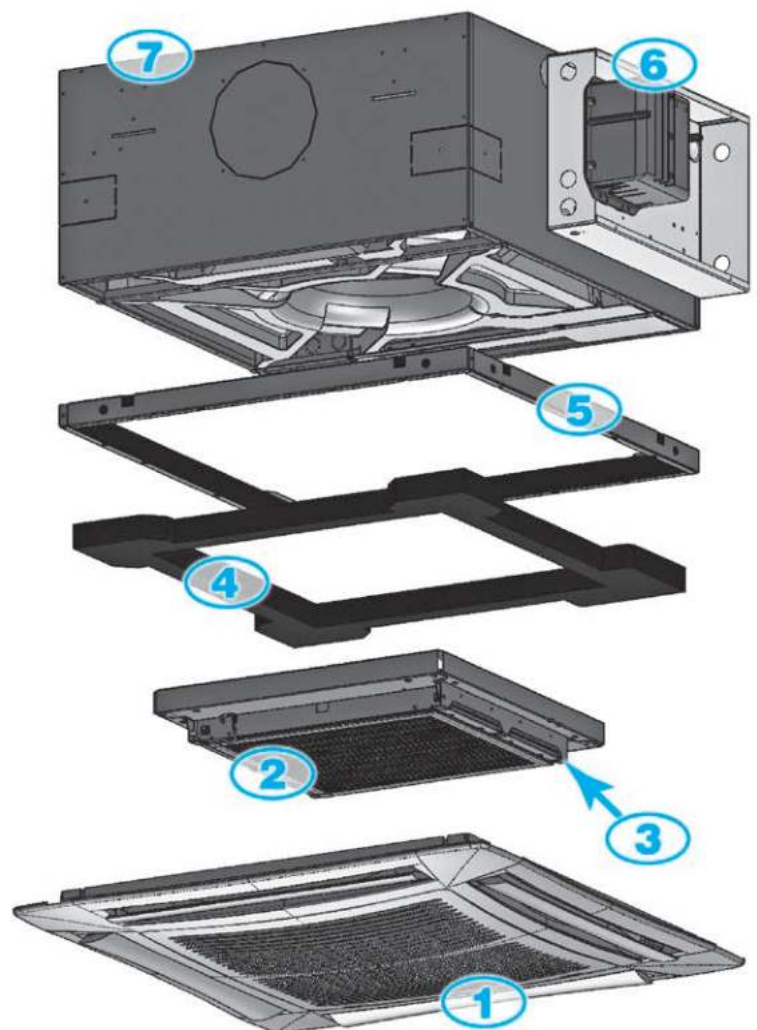

#### Control and regulation commands

Units with electrostatic filter can be controlled and regulated by the series of **IAQ** controls that are already provided for SEC fan coils.

- 1** - Diffuser with return air grid
- 2** - Active plate type electrostatic filter
- 3** - Plastic opening
- 4** - Insulation
- 5** - Filter containment frame
- 6** - Electronic board
- 7** - Cassette

## Wall electronic controls



If using the TopLine Cassette fan coils with electronic controllers, the voltage values at the autotransformer terminals must be kept in consideration (transformer return voltages). These values may reach 500 Vac.

IDENTIFICATION	CODE
WM-3V	9066642



Dimensions: 75x75x30 mm

- Manual 3 speed switch.
- Without thermostatic control.
- It can not control the valves.

IDENTIFICATION	CODE
WM-T	9066630E



Dimensions: 135x86x31 mm

- ON-OFF switch.
- Manual 3 speed switch.
- Manual Summer/Winter switch.
- Electronic room thermostat for fan control (ON-OFF).
- Electronic room thermostat for valve control (ON-OFF) (the fan keeps working).
- It allows to control the low temperature cut-out thermostat (TMM).
- It allows to control the chilled water valve (ON-OFF) and the electric heater (BEL) only in case that hot water is not used in winter (otherwise please use WM-TQR control with on/off switch for the electric heater).
- Presence of a LED signal when the thermostat is on.

Control power absorption: 0,25 VA

IDENTIFICATION	CODE
WM-TQR	9066631E



Dimensions: 135x86x31 mm

- ON-OFF switch.
- Manual 3 speed switch.
- Manual, automatic or centralized Summer/Winter switch.
- Electric heater/IAQ filter activation switch.
- Electronic room thermostat for fan control (ON-OFF).
- Electronic room thermostat for valve control (ON-OFF).
- Simultaneous thermostatic control of the valves and fan.
- It allows to control the low temperature cut-out thermostat (NTC).
- It allows to control the water valves (ON-OFF) and the electric heater managed as main heating element or as an integration element.
- Energy saving function.
- Presence of a LED signal when the thermostat is on.

Control power absorption: 1 VA



IDENTIFICATION	CODE
WM-AU	9066632E



Dimensions: 135x86x24 mm

The control must always be connected with UPM-AU power unit (fitted on the unit) or with UP-AU power unit (not fitted on the unit).

- ON-OFF switch and manual or automatic 3 speed progressive switch.
- Manual, automatic or centralized Summer/Winter switch.
- Summer/Winter/Fan/Auto mode switch.
- Electric heater/IAQ filter activation switch.
- Electronic room thermostat for fan and water valves control (ON-OFF).
- Simultaneous thermostatic control of the valves and fan.
- It allows to use the low temperature cut-out thermostat (NTC) mounted on the UP-AU power unit.
- It allows to control the water valves (ON-OFF) and the electric heater managed as main heating element or as an integration element.
- Energy saving switch and presence of a LED signal when the thermostat is on.

**N.B.:** with 4 pipe installations and continuous chilled and hot water supply, it allows the automatic summer winter change-over in accordance to the room temperature (-1°C = Winter, +1°C = Summer, Neutral Zone 2°C).

Control power absorption: see the UP-AU power unit

IDENTIFICATION	CODE
T-MB	9066331E



Dimensions: 110x72x25 mm

The control must always be connected with UPM-AU power unit (fitted on the unit) or with UP-AU power unit (not fitted on the unit).

Wall control with display that allows controlling one or more units in Master/Slave mode. The control is equipped with internal sensor to detect the room temperature, which can be defined as a priority compared to the return air sensor on the fan coil.

The T-MB control features the following functions:

- Switch the unit ON and OFF and temperature set.
- Manual, automatic or centralized Summer/Winter switch.
- Set the fan speed (low, medium, high or autofan).
- Set the operation mode (fan only, cooling, heating; auto for 4 pipe systems with mode selection depending on the air temperature).
- Possibility of use of the low temperature cut-out thermostat NTC mounted on the UP-AU power unit.
- It allows to control the water valves (ON-OFF) and the electric heater managed as main heating element or as an integration element.
- Time setting and weekly ON/OFF program.

Control power absorption: see the UP-AU power unit

IDENTIFICATION	CODE
WM-503	9066676E



Dimensions: 68x52.2x58 mm

The WM-503 control is designed to be installed in a 503 wall box.

Easy to use, it is equipped with a large and efficient backlit LCD screen with 4 keys.

The thermostat is delivered with an external frame conceived for several combinations with adaptors and covers that make it suitable for more than 25 different frames belonging to various brands.

- Manual or automatic 3 speed switch.
- One single digital input to select: ON-OFF/SETPOINT reduction/Summer-Winter switch.
- Electronic room thermostat for fan control (ON-OFF).
- Electronic room thermostat for 1 water valve control (ON-OFF) (2 pipe system).
- Electronic room thermostat for 2 water valves control (ON-OFF) (4 pipe system).
- Simultaneous thermostatic control of the valves and fan.
- One single input to select: return air/water/change-over control probe.
- Possibility to use a low temperature cut-out thermostat NTC (optional).

Control power absorption: see the UP-503 power unit

IDENTIFICATION	CODE
T2T	9060174



Dimensions: 128x75x25 mm

**2 pipes units only.**

- ON-OFF switch.
- Manual 3 speed switch.
- Manual Summer/Winter switch.
- Thermostatic control on the fan.
- Thermostatic control on the valve and continuous fan operation.
- Simultaneous thermostatic control of the valve and fan.
- Cannot be used with speed switch (master-slave).

Control power absorption: 1,5 VA

## Speed switches

IDENTIFICATION	CODE
SEL2M	9079109



- Speed switch (Slave).
- It allows to control up to 8 units with only one centralized wall control (1 speed switch for each unit).
- For controls WM-T and WM-TQR.

DESCRIPTION	IDENTIFICATION	CODE
Power unit for WM-AU and T-MB remote control (fitted on the unit)	UPM-AU	9066641
Power unit for WM-AU and T-MB remote control (not fitted on the unit)	UP-AU	9066640

Power unit to be installed on the fan coil (fan coil interface).

- It controls the fan and the valves of the fan coil.
- It is connected to the electric supply.
- It receives the information required from the control.
- Possibility to use the low temperature cut-out thermostat (optional) for the T1 function which allows the return air control.
- Possibility to use the low temperature cut-out thermostat (optional) for the T2 function which controls the summer/winter switch.
- Possibility to use the low temperature cut-out thermostat (optional) for the T3 function as low temperature cut-out thermostat.
- It allows to control up to 10 units (1 master and 9 slaves).
- Max. Network length: 100 meters.
- Max cable length between control and first connected power unit: 20 meters.

Control power absorption: 2,3 VA



IDENTIFICATION	CODE
UP-503	9066677



Power unit to be installed on the fan coil (fan coil interface).

- It controls the fan and the valves of the fan coil.
- It is connected to the electric supply.
- It receives the information required from the control WM-503.
- It allows to control up to 5 units (1 master and 4 slaves).
- Max. Network length: 100 meters.
- Max cable length between control and first connected power unit: 20 meters.

Control power absorption: 2 VA

## Wall electronic control accessories

### NTC low temperature cut-out thermostat

Suitable for wall controls only (not infra-red remote control). To be fitted between the coil fins; when connecting the control, the NTC probe cable must be separated from the power supply wires. To be used with WM-TQR control and UP-AU power unit.

It stops the fan when the water temperature is lower than 28°C and it starts the fan when is higher than 33°C.

To use as:

- T1 function for the return air control.
- T2 function which controls the summer/winter switch.
- T3 function as low temperature cut-out thermostat.

IDENTIFICATION	CODE
NTC	3021090



### TMM low temperature cut-out thermostat

To be installed in contact with the hot water circuit.

To be used only with WM-T control.

For units working on heating only.

It stops the fan when the water temperature is lower than 30°C and it starts the fan when is higher than 38°C.

IDENTIFICATION	CODE
TMM	9053048



### Change-Over CH 15-25

Suitable for wall controls only (not for infra-red remote control).

Automatic summer/winter switch

to be installed in contact with the water circuit.

For 2-tube installations only (not to be used with 2 way valve).

To be used only with WM-TQR control.

IDENTIFICATION	CODE
CH 15-25	9053049



### T2 sensor

T2 sensor to be placed on the water supply pipe upstream 3 way valves (not to be used with 2 way valve).

The T2 sensor must be used as described below:

- Change-Over for the automatic switch of the operating mode. If water temperature is lower than 20°C, cooling mode is set; on the other hand, if water temperature exceeds 30°C, heating mode is set.

To be used with UP-AU power unit.

IDENTIFICATION	CODE
T2	9025310

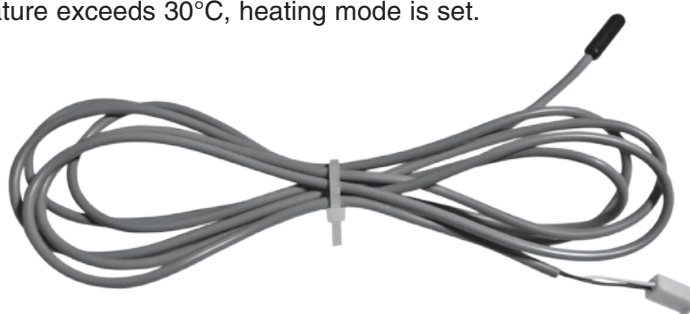

## Controls for **TL-MB** versions

All the **TopLine** units can be supplied in **MB version**. This version includes a wide range of controls, including the **infra-red remote control**, which allows managing one single unit or several units by using the **Modbus RTU - RS 485** communication protocol.

Units can be managed according to the Master/Slave logic (up to 20 units) or by supervisory components.

The system consists in a **MB board** (*mounted on models TL-MB and TL-ECM-MB*) and a series of controls, such as the **T-MB** wall control, the **RT03** infra-red remote control, the **PSM-DI** multifunction control and the **NET** supervisory program.



***T-MB wall control***



***PSM-DI multifunction control***



***RT03 infra-red remote control***

***NET screenshot***

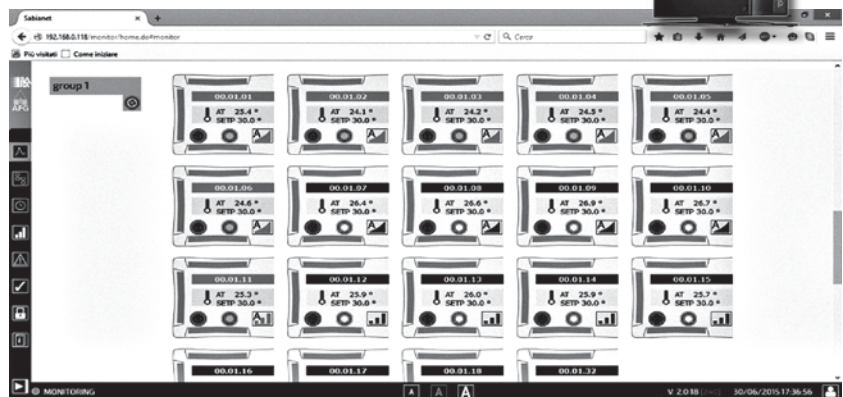

***PC***

***NET software***

*All the controls for the **ECM** version and their functions are described in detail from Page 50.*

## Electric resistance TL-E

The Cassette 2 pipe models are available with electric resistance that is controlled in place of the heating battery valve. The electric resistance is controlled in place of the hot water valve and not as integration to it. The resistance is hermetically sealed and supplied inside the battery pipes and therefore can be only factory mounted. The electric resistances of the units are for single phase 230V supply. The Cassette includes no. 2 safety thermostats which intervene in case of internal over- heating, opening an auxiliary power relay (included in the shunt box) which stops the power supply to the resistances.

Model	TL 1.2T-E	TL 2.2T-E / TL 3.2T-E	TL 4.2T-E / TL 5.2T-E / TL 6.2T-E
Emission	1500 Watt	2500 Watt	3000 Watt
Supply	230V ~	230V ~	230V ~
Number and Dia. of connecting wires	3 x 1,5 mm <sup>2</sup>	3 x 2,5 mm <sup>2</sup>	3 x 2,5 mm <sup>2</sup>

**Note: the cooling emission of the units is 95% of the emission in the tables of page 6.**

## Electric diagram

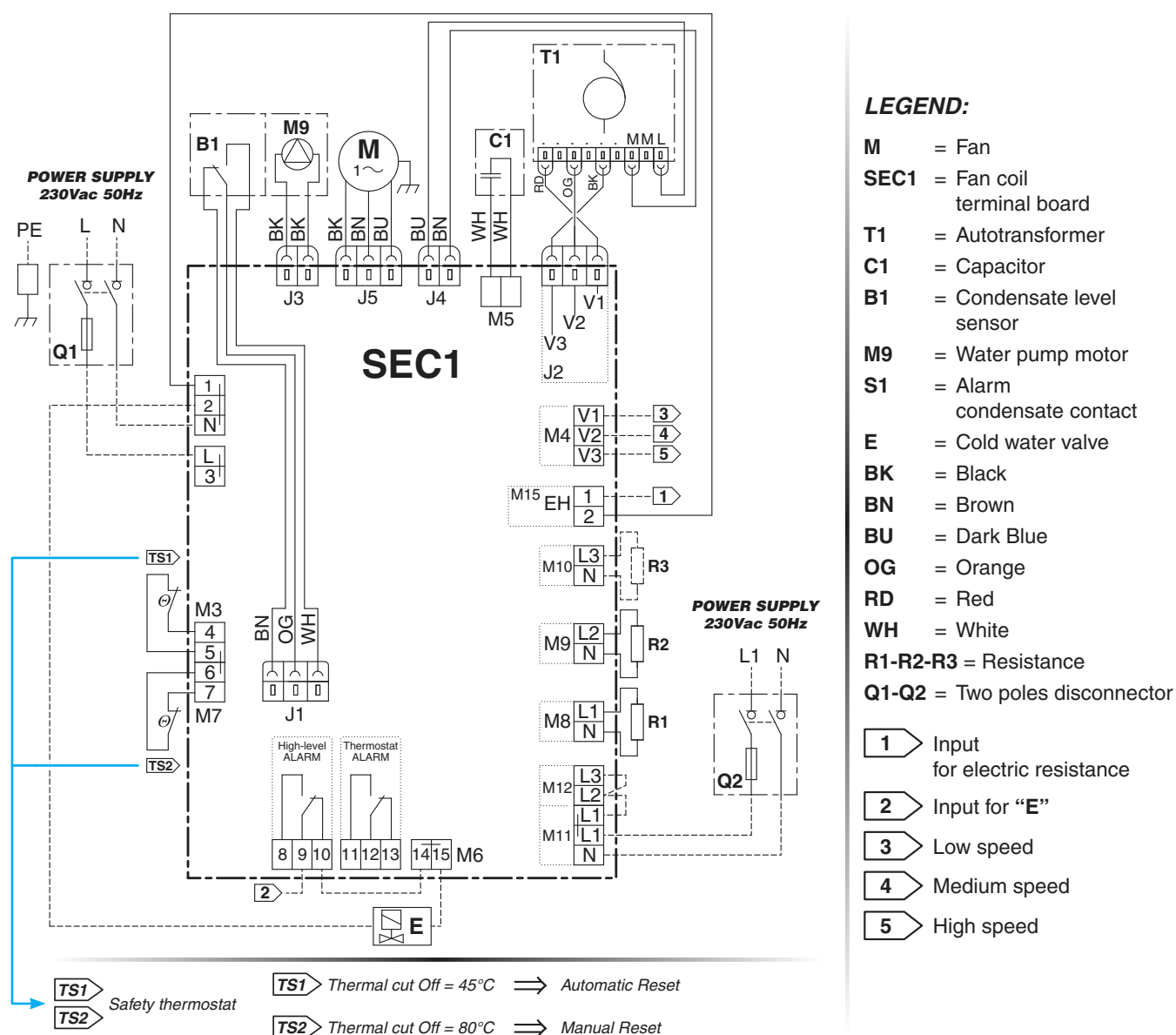

## Cassette unit operating limits with electric coil

Max. ambient temperature for Cassette unit with electric coil in heating mode: 25°C

## Introduction

The TopLine ECM series uses an innovative brushless synchronous permanent magnet electric motor controlled by an inverter card that is directly installed on the unit.

The air flow can be varied **continuously** with a 1-10 V signal from our controls or by independent controllers (programmable controllers with a 1-10 V output).

The extreme efficiency, also at a low speed, makes possible a great reduction in electric consumption (**more than 75% less in comparison to a traditional motor**) with absorption values, under normal operating conditions, that are **no greater than 10 Watt** in the entire range.

The brushless motor is characterised by a constant synchronous speed, independently of the applied load, that depends only on the motor power supply frequency, which is modulated by the inverter. It consumes less because:

- The motor always works at its point of maximum efficiency.
- In the brushless motor, the rotor's permanent magnets generate the magnetising power autonomously.
- The motor always operates at the synchronous speed, as a result there are no induced currents that reduce efficiency.

The main advantages are:

- Large reduction in energy consumption, thanks to an optimal response to the thermal load of the environment during every moment of the day.
- Operating silence at all rotation speeds.
- Ability to operate at any rotation speed.

### MOTOR ABSORPTION

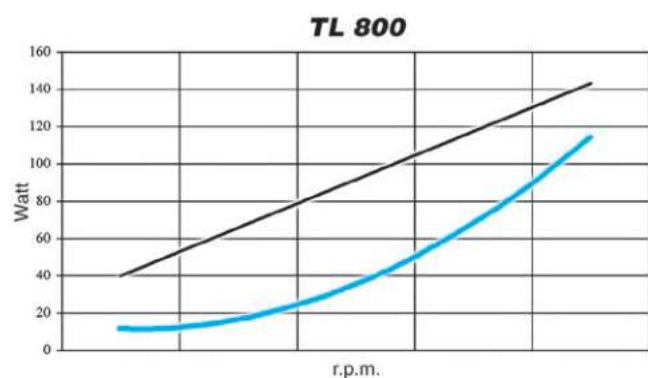
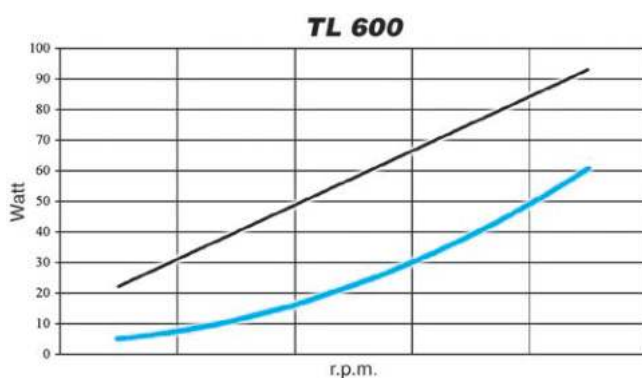

———— = TL      ————— = TL-ECM

## Main components

### INTAKE GRID AND DISTRIBUTION OF THE AIR

Intake grids, frame and adjustable air distribution louvers on each side, made from ABS.

*RSNA version:* white ABS, RAL 9003

*RSNB version:* with intake grid, frame and louvers, choice of one colour only

*RSNC version:* with intake grid and louvers, choice of one colour, plus white ABS frame RAL 9003

*RSND version:* with louvers, choice of one colour, while the grid and frame are made from ABS, RAL 9003

*MD-600 version/MD-800 version:* metal diffuser painted in RAL 9003 white colour with 600x600 dimension to perfectly fit into the false ceiling standard modules without overlapping parts.

### CASING

Is made from galvanized steel with internal thermal insulation with polyolefin (PO) foam (class M1) and external anti-condensate lining.

### CONTROL EQUIPMENT

*TL-ECM version*

It consists of the pump control circuit board and the inverter circuit board.

*TL-ECM-MB version*

It consists of the MB electronic board (that integrates pump control) and the inverter board.

### FAN ASSEMBLY

The fan assembly, which is mounted on anti-vibrating supports, is extremely silent.

The radial fan has been designed to optimise performance, using wing profile blades with a shape that reduces turbulence, increasing efficiency and reducing noise.

The fans are connected to a three phase permanent magnet brushless electronic motor that is controlled with reconstructed current according to a BLAC sinusoidal wave.

The inverter board that controls the motor operation is powered by 230 Volt, single-phase and, with a switching system, it generates a three-phase frequency modulated, wave form power supply.

The electric power supply required for the machine is therefore single-phase with voltage of 230 - 240 V and frequency of 50 - 60 Hz.

### COIL

Made of copper tubes with bonded aluminium fins for maximum transfer contact.

The coil has 2 or 3 rows for 2 pipe models and 2+1 rows for 4 pipe models (the heating row is on the inside part of the coil).

For 4 pipe systems two versions are available:

TL 1.4T and TL 4.4T supply an higher heating emission;

TL 2.6T, TL 3.6T, TL 5.6T supply an higher cooling emission.

The heat exchanger is not suitable for use in corrosive atmosphere or in environments where aluminium may be subject to corrosion.

### CONDENSATE COLLECTION TRAY

High density ABS polystyrene foam condensate tray, shaped in order to optimize the air diffusion, fire retardant rating B1 to DIN 4102.

### AIR FILTER

Synthetic washable filter, easily removable.

### CONDENSATE PUMP

Float switch centrifugal pump with 650 mm of maximum head, integral to the unit and wired to the control panel on the outside of the casing.

### VALVE SET

Two or three way valves for ON/OFF operation, with pipe mounting kit and thermostatic actuator.

## Technical features

**2 pipe units.** The following standard rating conditions are used:

### COOLING

Entering air temperature +27°C d.b. +19°C w.b.  
 Water temperature +7°C E.W.T. +12°C L.W.T.

### HEATING

Entering air temperature +20°C  
 Water temperature +45°C E.W.T. +40°C L.W.T.

MODEL		TL-ECM 1.2T					TL-ECM 2.2T					TL-ECM 3.2T				
		1	3	5	7,5	10	1	3	5	7,5	10	1	3	5	7,5	10
Speed		LOW		MED		HIGH	LOW		MED		HIGH	LOW		MED		HIGH
Air flow	m <sup>3</sup> /h	310	345	380	457	535	310	377	445	577	710	360	485	610	745	880
Cooling total emission	kW	1,84	2,01	2,16	2,47	2,73	2,24	2,65	3,04	3,71	4,30	2,55	3,25	3,85	4,45	4,96
Cooling sensible emission	kW	1,35	1,47	1,60	1,84	2,07	1,57	1,87	2,16	2,67	3,15	1,80	2,31	2,79	3,25	3,68
Heating	kW	1,85	2,04	2,22	2,55	2,87	2,12	2,56	2,98	3,68	4,36	2,46	3,17	3,85	4,52	5,15
Dp Cooling	kPa	4,9	5,8	6,6	8,4	10,1	4,6	6,3	11,0	11,6	15,1	5,9	9,1	12,4	16,2	19,7
Dp Heating	kPa	4,3	5,1	5,9	7,6	9,4	3,6	5,1	6,6	9,7	13,2	4,7	7,5	10,6	14,1	17,8
Fan	W	5	6,5	8	12	16	5	8	11	21	31	7	14	21	41,5	62
Sound power Lw	dB(A)	33	36	39	43	47	33	38	43	48,5	54	37	43,5	50	55	60
Sound pressure Lp (*)	dB(A)	24	27	30	34	38	24	29	34	39,5	45	28	34,5	41	46	51
Water content	l	1,4					2,1					2,1				
Dimensions	mm	575 x 575 x 275														

MODEL		TL-ECM 4.2T					TL-ECM 5.2T				
		1	3	5	7,5	10	1	3	5	7,5	10
Speed		LOW		MED		HIGH	LOW		MED		HIGH
Air flow	m <sup>3</sup> /h	630	750	870	1017	1165	710	920	1130	1450	1770
Cooling total emission	kW	4,20	4,70	5,13	5,76	6,30	5,28	6,54	7,69	9,28	10,69
Cooling sensible emission	kW	3,02	3,39	3,75	4,23	4,69	3,68	4,62	5,50	6,71	7,83
Heating	kW	4,27	4,78	5,30	6,02	6,70	4,90	6,18	7,34	9,00	10,56
Dp Cooling	kPa	10,9	13,3	15,6	19,3	22,7	9,4	13,8	18,5	26,1	33,0
Dp Heating	kPa	9,6	11,8	14,2	17,9	21,6	7,0	10,7	14,6	21,1	28,1
Fan	W	10	13,5	17	25	33	10	21	32	70	108
Sound power Lw	dB(A)	33	36	39	43,5	48	34	40,5	47	52	57
Sound pressure Lp (*)	dB(A)	24	27	30	34,5	39	25	31,5	38	43	48
Water content	l	3,0					4,0				
Dimensions	mm	820 x 820 x 303									

**Condensate pump absorption: 10 W**

(\*) = The sound pressure levels are 9 dB(A) lower than the sound power levels and apply to the reverberant field of a 100 m<sup>3</sup> room and a reverberation time of 0.5 sec.



## Technical features

**4 pipe units.** The following standard rating conditions are used:

### COOLING

Entering air temperature +27°C d.b. +19°C w.b.  
 Water temperature +7°C E.W.T. +12°C L.W.T.

### HEATING

Entering air temperature +20°C  
 Water temperature +65°C E.W.T. +55°C L.W.T.

MODEL		TL-ECM 1.4T					TL-ECM 2.6T					TL-ECM 3.6T				
		1	3	5	7,5	10	1	3	5	7,5	10	1	3	5	7,5	10
Speed		LOW		MED		HIGH	LOW		MED		HIGH	LOW		MED		HIGH
Air flow	m³/h	310	345	380	457	535	310	377	445	577	710	360	485	610	745	880
Cooling total emission	kW	1,85	2,02	2,17	2,48	2,75	2,09	2,46	2,81	3,39	3,90	2,37	2,99	3,51	4,03	4,47
Cooling sensible emission	kW	1,34	1,47	1,59	1,83	2,06	1,49	1,76	2,03	2,49	2,92	1,70	2,17	2,60	3,01	3,40
Heating	kW	2,13	2,32	2,51	2,85	3,18	1,73	1,97	2,20	2,57	2,91	1,92	2,31	2,66	2,99	3,29
Dp Cooling	kPa	4,6	5,4	6,2	7,9	9,5	3,3	4,4	5,6	7,9	10,3	4,1	6,3	8,4	10,9	13,1
Dp Heating	kPa	4,6	5,3	6,1	7,7	9,4	2,6	3,3	4,1	5,4	6,7	3,2	4,4	5,7	7,1	8,4
Fan	W	5	6,5	8	12	16	5	8	11	21	31	7	14	21	41,5	62
Sound power Lw	dB(A)	33	36	39	43	47	33	38	43	48,5	54	37	43,5	50	55	60
Sound pressure Lp (*)	dB(A)	24	27	30	34	38	24	29	34	39,5	45	28	34,5	41	46	51
Cooling water content	l	1,4					1,7					1,7				
Heating water content	l	0,7					0,5					0,5				
Dimensions	mm	575 x 575 x 275														

MODEL		TL-ECM 4.4T					TL-ECM 5.6T				
		1	3	5	7,5	10	1	3	5	7,5	10
Speed		LOW		MED		HIGH	LOW		MED		HIGH
Air flow	m³/h	630	750	870	1017	1165	710	920	1130	1450	1770
Cooling total emission	kW	4,29	4,81	5,29	5,92	6,48	4,97	6,13	7,14	8,56	9,76
Cooling sensible emission	kW	3,07	3,46	3,82	4,32	4,80	3,51	4,37	5,17	6,27	7,29
Heating	kW	5,41	6,04	6,65	7,46	8,24	4,58	5,47	6,27	7,36	8,33
Dp Cooling	kPa	9,4	11,6	13,6	16,8	19,8	8,8	12,9	17,0	23,7	30,1
Dp Heating	kPa	8,5	10,3	12,3	15,1	18,1	4,9	6,7	8,6	11,4	14,3
Fan	W	10	13,5	17	25	33	10	21	32	70	108
Sound power Lw	dB(A)	33	36	39	43,5	48	34	40,5	47	52	57
Sound pressure Lp (*)	dB(A)	24	27	30	34,5	39	25	31,5	38	43	48
Cooling water content	l	3,0					3,6				
Heating water content	l	1,4					1,1				
Dimensions	mm	820 x 820 x 303									

### Condensate pump absorption: 10 W

(\*) = The sound pressure levels are 9 dB(A) lower than the sound power levels and apply to the reverberant field of a 100 m³ room and a reverberation time of 0.5 sec.

## Emission

### Cooling emission of 1 battery units (2 pipe installation)

Entering air temperature: +27°C d.b. – +19°C w.b.

ECM MOD.	Speed	Vdc	Qv m³/h	WT: 7/12 °C			WT: 8/13 °C			WT: 10/15 °C			WT: 12/17 °C		
				Qw l/h	Pc kW	Ps kW	Qw l/h	Pc kW	Ps kW	Qw l/h	Pc kW	Ps kW	Qw l/h	Pc kW	Ps kW
TL 1.2T	MAX	10	535	506	2,94	2,06	455	2,64	1,94	307	1,78	1,78	263	1,53	1,53
		7,5	457	455	2,64	1,84	409	2,38	1,73	323	1,88	1,52	234	1,36	1,36
	MED	5	380	399	2,32	1,60	360	2,09	1,50	284	1,65	1,32	206	1,20	1,20
		3	345	370	2,15	1,47	334	1,94	1,38	264	1,54	1,22	190	1,10	1,10
TL 2.2T	MAX	10	710	792	4,61	3,14	716	4,16	2,95	566	3,29	2,60	404	2,35	2,35
		7,5	577	681	3,96	2,67	617	3,59	2,51	490	2,85	2,20	379	2,20	1,93
	MED	5	445	559	3,25	2,16	508	2,95	2,03	403	2,35	1,78	312	1,81	1,56
		3	377	487	2,83	1,87	442	2,57	1,76	354	2,06	1,54	274	1,59	1,35
TL 3.2T	MAX	10	880	916	5,32	3,67	825	4,80	3,45	653	3,80	3,04	471	2,74	2,74
		7,5	745	817	4,75	3,24	738	4,29	3,05	585	3,40	2,69	417	2,43	2,43
	MED	5	610	710	4,13	2,79	643	3,74	2,62	510	2,97	2,31	394	2,29	2,02
		3	485	596	3,46	2,31	541	3,14	2,17	429	2,49	1,91	332	1,93	1,67
TL 4.2T	MAX	10	1165	1162	6,76	4,67	1049	6,10	4,40	826	4,80	3,88	599	3,48	3,48
		7,5	1017	1057	6,15	4,22	955	5,55	3,97	755	4,39	3,49	541	3,14	3,14
	MED	5	870	945	5,50	3,74	856	4,97	3,52	675	3,93	3,10	480	2,79	2,79
		3	750	861	5,01	3,39	780	4,54	3,19	619	3,60	2,80	438	2,55	2,55
TL 5.2T	MAX	10	1770	1962	11,41	7,81	1772	10,30	7,35	1410	8,20	6,48	1012	5,89	5,89
		7,5	1450	1702	9,90	6,70	1541	8,96	6,29	1227	7,14	5,55	951	5,53	4,87
	MED	5	1130	1415	8,22	5,49	1281	7,45	5,17	1026	5,96	4,54	791	4,60	3,98
		3	920	1200	6,98	4,61	1090	6,34	4,34	875	5,09	3,81	675	3,92	3,33
	MIN	1	710	968	5,63	3,68	881	5,12	3,46	710	4,13	3,04	550	3,20	2,66

#### Emission correction factors for different working conditions

Multiply the factors by the emission figures in the 7-12°C table above.

Note: the correction factors are indicative, as they are average values.

Water (°C)	Air (°C)	TOTAL EMISSION			Air (°C)	SENSIBLE EMISSION		
		25 - 18	26 - 18.5	28 - 20		25 - 18	26 - 18.5	28 - 20
7/12	K	0,82	0,89	1,11	K	0,90	0,94	1,06
10/15	K	0,56	0,63	0,82	K	0,72	0,78	0,90
14/18	K	0,35	0,41	0,52	K	0,50	0,58	0,72

#### LEGEND

- WT = Water temperature
- Pc = Cooling total emission
- Ps = Cooling sensible emission
- Qw = Water flow
- Speed = Fan speed
- MAX = High speed
- MED = Medium speed
- MIN = Low speed
- Vdc = Inverter Power
- Qv = Air flow

## Emission

### Heating emission of 1 battery units (2 pipe installation)

Entering air temperature: +20°C

				WT: 45/40 °C			WT: 50/40 °C			WT: 55/45 °C			WT: 60/50 °C			WT: 70/60 °C		
ECM MOD.	Speed	Vdc	Qv	Qw	Ph	Qw	Ph	Qw	Ph	Qw	Ph	Qw	Ph	Qw	Ph	Qw	Ph	
			m³/h	l/h	kW	l/h	kW	l/h	kW	l/h	kW	l/h	kW	l/h	kW	l/h	kW	
<b>TL 1.2T</b>	MAX	10	535	247	2,87	272	3,17	330	3,83	387	4,49	500	5,82					
		7,5	457	219	2,55	243	2,82	293	3,41	343	3,99	444	5,16					
	MED	5	380	191	2,22	213	2,48	257	2,99	300	3,49	387	4,51					
		3	345	176	2,04	196	2,28	236	2,74	276	3,21	355	4,13					
	MIN	1	310	159	1,85	178	2,07	214	2,49	250	2,91	322	3,75					
<b>TL 2.2T</b>	MAX	10	710	375	4,36	420	4,89	505	5,87	589	6,85	758	8,81					
		7,5	577	317	3,68	357	4,15	428	4,97	499	5,80	640	7,44					
	MED	5	445	256	2,98	290	3,38	347	4,04	404	4,70	517	6,01					
		3	377	220	2,56	251	2,92	300	3,48	348	4,05	444	5,16					
	MIN	1	310	183	2,12	209	2,43	249	2,90	289	3,36	368	4,28					
<b>TL 3.2T</b>	MAX	10	880	443	5,15	494	5,75	595	6,92	696	8,09	896	10,42					
		7,5	745	389	4,52	435	5,06	524	6,09	611	7,11	786	9,14					
	MED	5	610	331	3,85	373	4,34	448	5,20	522	6,07	670	7,79					
		3	485	273	3,17	309	3,59	370	4,30	430	5,01	551	6,41					
	MIN	1	360	212	2,46	241	2,81	288	3,35	335	3,89	427	4,96					
<b>TL 4.2T</b>	MAX	10	1165	576	6,70	642	7,47	774	9,00	904	10,51	1165	13,54					
		7,5	1017	517	6,02	579	6,73	696	8,10	813	9,46	1046	12,16					
	MED	5	870	456	5,30	512	5,95	615	7,15	717	8,34	922	10,72					
		3	750	411	4,78	463	5,38	555	6,45	647	7,52	830	9,65					
	MIN	1	630	367	4,27	415	4,82	497	5,78	578	6,72	741	8,61					
<b>TL 5.2T</b>	MAX	10	1770	908	10,56	1015	11,81	1222	14,21	1428	16,60	1837	21,37					
		7,5	1450	774	9,00	870	10,11	1045	12,15	1219	14,17	1565	18,20					
	MED	5	1130	631	7,34	713	8,29	854	9,93	994	11,56	1274	14,82					
		3	920	532	6,18	604	7,02	722	8,40	839	9,76	1073	12,47					
	MIN	1	710	421	4,90	481	5,60	574	6,67	666	7,74	849	9,87					

#### LEGEND

- WT = Water temperature
- Ph = Emission
- Qw = Water flow
- Speed = Fan speed
- MAX = High speed
- MED = Medium speed
- MIN = Low speed
- Vdc = Inverter Power
- Qv = Air flow

## Emission of 4 pipe units with standard and enhanced cooling battery

### Cooling emission of 2 battery units (4 pipe installation)

Entering air temperature: +27°C d.b. – +19°C w.b.

ECM MOD.	Speed	Vdc	Qv m³/h	WT: 7/12 °C			WT: 8/13 °C			WT: 10/15 °C			WT: 12/17 °C		
				Qw l/h	Pc kW	Ps kW	Qw l/h	Pc kW	Ps kW	Qw l/h	Pc kW	Ps kW	Qw l/h	Pc kW	Ps kW
TL 1.4T	MAX	10	535	508	2,95	2,05	458	2,66	1,93	305	1,77	1,77	261	1,52	1,52
		7,5	457	456	2,65	1,83	412	2,39	1,72	325	1,89	1,52	235	1,37	1,37
	MED	5	380	401	2,33	1,59	362	2,10	1,50	286	1,66	1,32	204	1,19	1,19
		3	345	371	2,16	1,47	336	1,95	1,38	265	1,54	1,21	188	1,09	1,09
	MIN	1	310	340	1,98	1,33	308	1,79	1,26	242	1,41	1,10	171	0,99	0,99
TL 2.6T	MAX	10	710	720	4,19	2,91	648	3,77	2,73	513	2,98	2,41	372	2,16	2,16
		7,5	577	623	3,62	2,49	562	3,27	2,34	446	2,59	2,06	319	1,85	1,85
	MED	5	445	516	3,00	2,03	467	2,71	1,91	369	2,15	1,68	261	1,52	1,52
		3	377	452	2,63	1,76	409	2,38	1,66	326	1,90	1,46	251	1,46	1,28
	MIN	1	310	383	2,23	1,48	347	2,02	1,39	277	1,61	1,22	214	1,24	1,07
TL 3.6T	MAX	10	880	826	4,80	3,38	742	4,31	3,18	586	3,41	2,81	431	2,51	2,51
		7,5	745	742	4,31	3,00	667	3,88	2,82	527	3,06	2,49	384	2,23	2,23
	MED	5	610	649	3,77	2,60	585	3,40	2,44	462	2,69	2,15	333	1,94	1,94
		3	485	548	3,19	2,17	496	2,88	2,04	393	2,28	1,79	278	1,62	1,62
	MIN	1	360	436	2,54	1,70	395	2,30	1,60	314	1,83	1,40	243	1,41	1,23
TL 4.4T	MAX	10	1165	1196	6,95	4,79	1080	6,28	4,50	851	4,95	3,96	613	3,56	3,56
		7,5	1017	1086	6,31	4,31	982	5,71	4,06	775	4,51	3,57	553	3,21	3,21
	MED	5	870	969	5,64	3,82	878	5,10	3,59	697	4,05	3,16	495	2,88	2,88
		3	750	882	5,13	3,45	800	4,65	3,25	634	3,69	2,86	447	2,60	2,60
	MIN	1	630	790	4,59	3,07	717	4,17	2,89	567	3,30	2,54	439	2,55	2,22
TL 5.6T	MAX	10	1770	1801	10,47	7,26	1623	9,44	6,83	1286	7,48	6,03	933	5,42	5,42
		7,5	1450	1571	9,14	6,25	1419	8,25	5,88	1123	6,53	5,18	805	4,68	4,68
	MED	5	1130	1315	7,65	5,17	1191	6,93	4,86	942	5,48	4,27	731	4,25	3,74
		3	920	1123	6,53	4,36	1019	5,93	4,10	810	4,71	3,60	625	3,63	3,16
	MIN	1	710	913	5,31	3,51	831	4,83	3,30	664	3,86	2,90	514	2,99	2,53

### Emission correction factors for different working conditions

Multiply the factors by the emission figures in the 7-12°C table above.

Note: the correction factors are indicative, as they are average values.

Water (°C)	Air (°C)	TOTAL EMISSION			Air (°C)	SENSIBLE EMISSION		
		25 - 18	26 - 18.5	28 - 20		25 - 18	26 - 18.5	28 - 20
7/12	K	0,82	0,89	1,11	K	0,90	0,94	1,06
10/15	K	0,56	0,63	0,82	K	0,72	0,78	0,90
14/18	K	0,35	0,41	0,52	K	0,50	0,58	0,72

### LEGEND

- WT = Water temperature
- Pc = Cooling total emission
- Ps = Cooling sensible emission
- Qw = Water flow
- Speed = Fan speed
- MAX = High speed
- MED = Medium speed
- MIN = Low speed
- Vdc = Inverter Power
- Qv = Air flow

## Emission of 4 pipe units with standard and enhanced cooling battery

### Heating emission of 2 battery units (4 pipe installation)

Entering air temperature: +20°C

ECM MOD.	Speed	Vdc	Qv m³/h	WT: 45/40 °C		WT: 50/40 °C		WT: 55/45 °C		WT: 60/50 °C		WT: 70/60 °C	
				Qw l/h	Ph kW	Qw l/h	Ph kW	Qw l/h	Ph kW	Qw l/h	Ph kW	Qw l/h	Ph kW
TL 1.4T	MAX	10	535	153	1,78	161	1,87	198	2,30	236	2,74	311	3,62
		7,5	457	137	1,59	144	1,68	178	2,07	212	2,46	279	3,24
	MED	5	380	120	1,40	127	1,48	156	1,82	186	2,16	245	2,85
		3	345	112	1,30	118	1,37	145	1,69	172	2,01	227	2,64
	MIN	1	310	103	1,19	108	1,26	133	1,55	158	1,84	209	2,43
TL 2.6T	MAX	10	710	139	1,62	139	1,61	176	2,04	213	2,48	288	3,35
		7,5	577	123	1,43	123	1,43	156	1,81	189	2,19	254	2,96
	MED	5	445	105	1,23	106	1,23	133	1,55	161	1,87	217	2,53
		3	377	95	1,10	95	1,11	120	1,39	145	1,68	195	2,27
	MIN	1	310	83	0,96	83	0,97	105	1,22	127	1,47	170	1,98
TL 3.6T	MAX	10	880	158	1,83	156	1,82	198	2,31	241	2,80	326	3,79
		7,5	745	143	1,67	142	1,66	181	2,10	219	2,54	296	3,44
	MED	5	610	127	1,48	127	1,48	161	1,87	195	2,27	263	3,06
		3	485	111	1,29	111	1,29	140	1,63	170	1,97	229	2,66
	MIN	1	360	92	1,07	93	1,08	117	1,36	141	1,64	189	2,20
TL 4.4T	MAX	10	1165	396	4,61	421	4,90	517	6,01	613	7,13	805	9,36
		7,5	1017	359	4,17	382	4,44	468	5,45	555	6,46	729	8,48
	MED	5	870	320	3,72	340	3,96	417	4,85	494	5,75	649	7,54
		3	750	291	3,38	310	3,60	380	4,41	450	5,23	590	6,86
	MIN	1	630	260	3,03	278	3,23	340	3,96	403	4,68	528	6,14
TL 5.6T	MAX	10	1770	400	4,65	413	4,80	514	5,97	615	7,15	818	9,51
		7,5	1450	353	4,11	365	4,25	454	5,28	543	6,32	722	8,40
	MED	5	1130	301	3,50	312	3,63	388	4,51	464	5,39	616	7,16
		3	920	263	3,06	273	3,18	339	3,94	405	4,70	537	6,24
	MIN	1	710	220	2,56	229	2,67	284	3,30	339	3,94	449	5,22

#### LEGEND

- WT = Water temperature
- Ph = Emission
- Qw = Water flow
- Speed = Fan speed
- MAX = High speed
- MED = Medium speed
- MIN = Low speed
- Vdc = Inverter Power
- Qv = Air flow

## Water side pressure drop

### 2 pipe installation

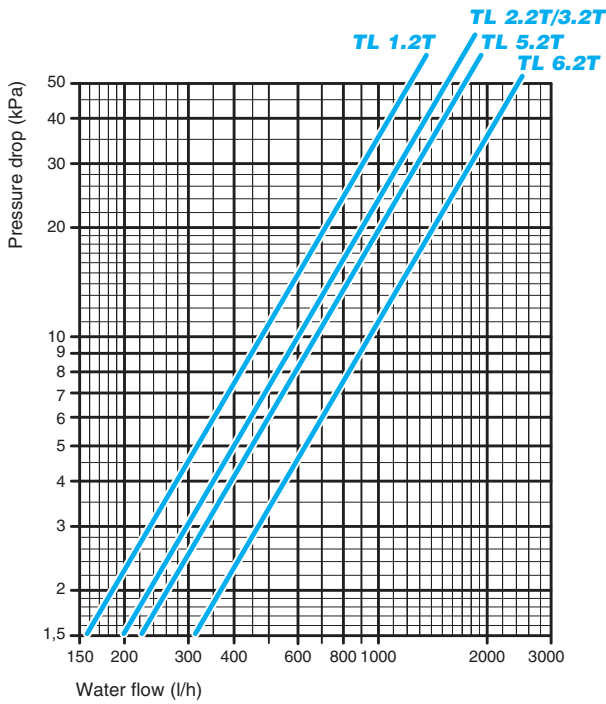

The water pressure drop figures refer to a mean water temperature of **10°C**; for different temperatures, multiply the pressure drop figures by the correction factors **K**.

°C	20	30	40	50	60	70	80
<b>K</b>	0,94	0,90	0,86	0,82	0,78	0,74	0,70

### 4 pipe installation

#### Pressure drop for cooling battery

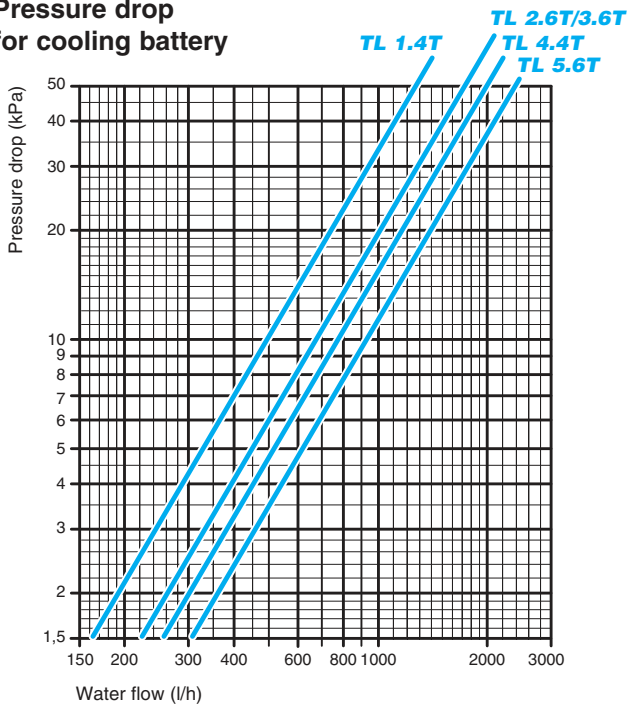

The water pressure drop figures refer to a mean water temperature of **10°C**; for different temperatures, multiply the pressure drop figures by the correction factors **K**.

°C	20	30	40	50	60	70	80
<b>K</b>	0,94	0,90	0,86	0,82	0,78	0,74	0,70

#### Pressure drop for heating battery

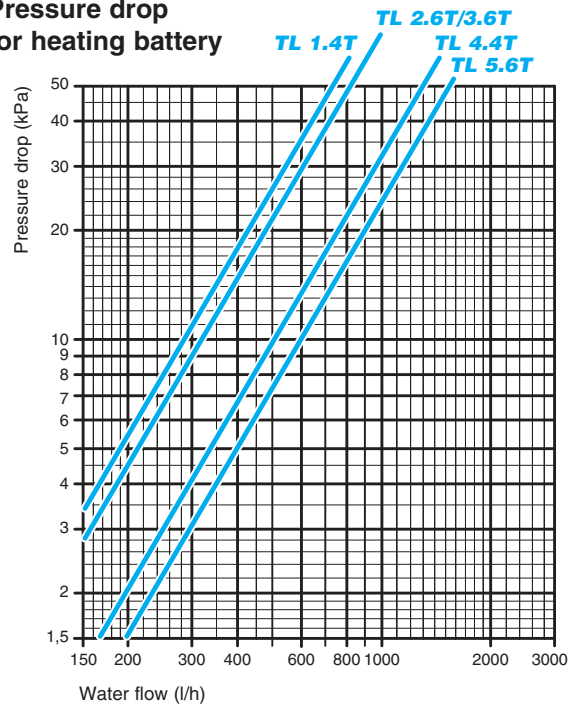

The water pressure drop figures refer to a mean water temperature of **60°C**; for different temperatures, multiply the pressure drop figures by the correction factors **K**.

°C	40	50	70	80
<b>K</b>	1,12	1,06	0,94	0,88

## Working conditions

<b>Water flow</b>	MAX. working pressure: 8 bars	MIN. entering water temperature: +5°C ----- MAX. entering water temperature: +80°C
<b>Air flow</b>	Suitable relative humidity: 15-75%	MIN. entering air temperature: +6°C ----- MAX. entering air temperature: +40°C
<b>Supply</b>	Single phase 230V / 50Hz	
<b>Installation</b>	MAX. height: see table on page 12	



## Dimensions and weights

**TL 1.2T-1.4T/TL 2.2T-2.6T/TL 3.2T-3.6T** (Version 600 x 600)

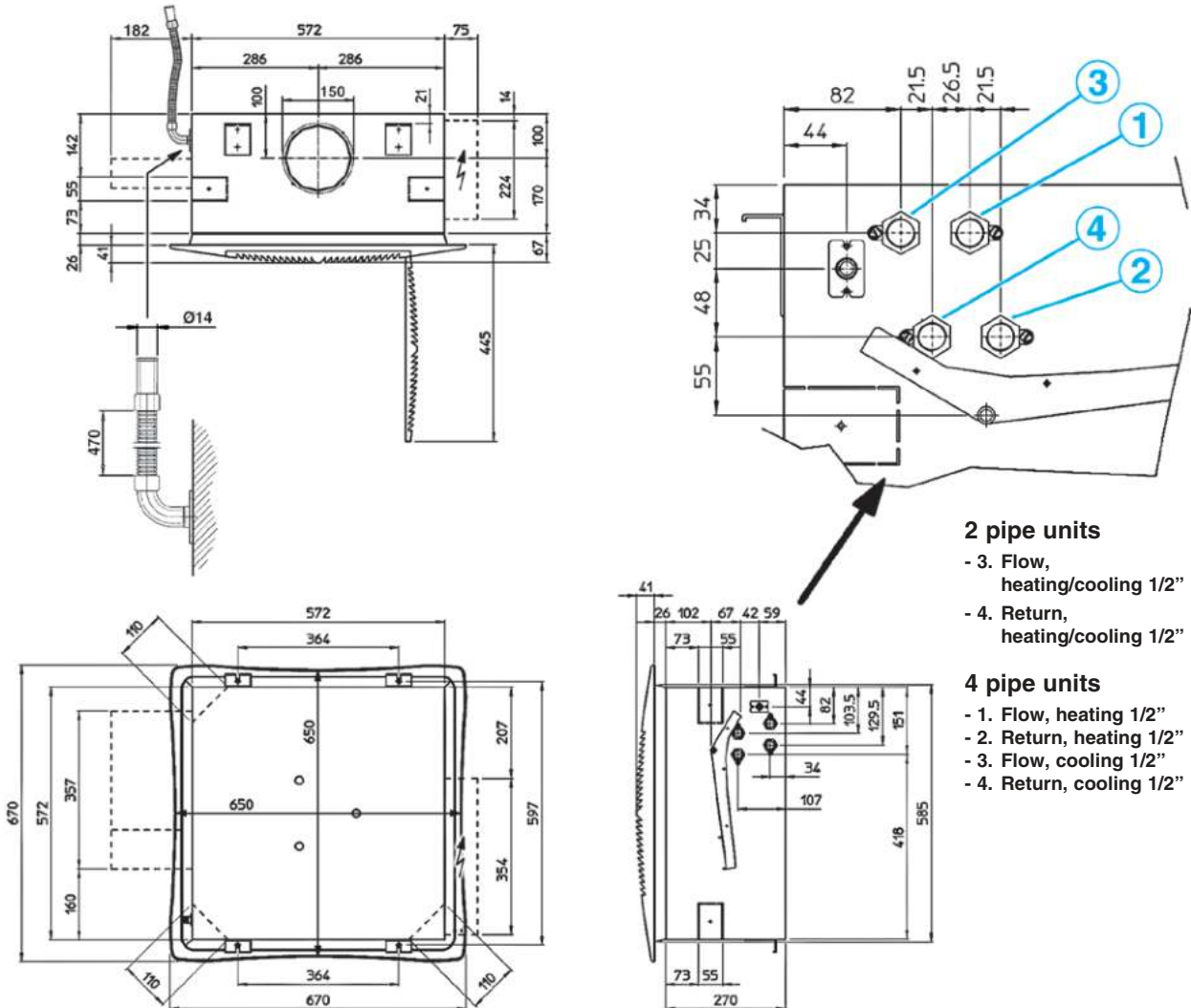

### **MD-600/MD-800 METAL DIFFUSER**

(RS receiver, Code 9066338, for MD-600/MD-800 metal diffuser for MP units)

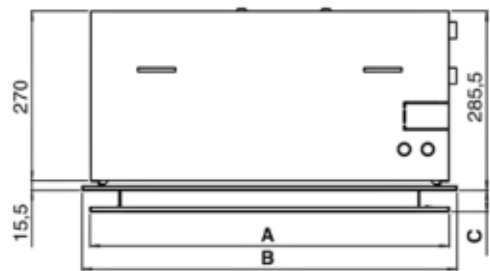
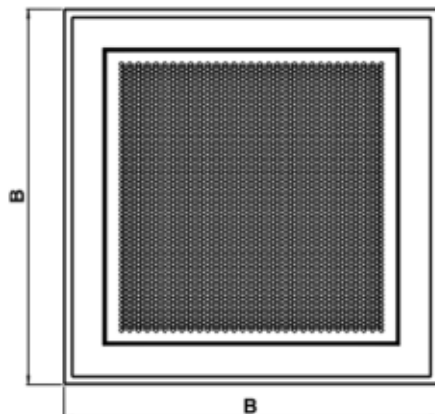

Size	A	B	C	Code
<b>MD-600</b>	574	599	34,5	9079420
<b>MD-800</b>	845	880	45,5	9079417

ECM Model	UNIT		DIFFUSER		Packed unit Dimensions			
	Weights packed unit	Weights unpacked unit	Weights packed unit	Weights unpacked unit	A	B	C	D
	kg	kg	kg	kg	mm			
<b>TL 1.2T</b>	28	22	6	3	790	350	750	150
<b>TL 1.4T</b>	30	24						
<b>TL 2.2T / 2.6T</b>								
<b>TL 3.2T / 3.6T</b>								



## Dimensions and weights

**TL 4.2T-4.4T/TL 5.2T-5.6T** (Version 800 x 800)

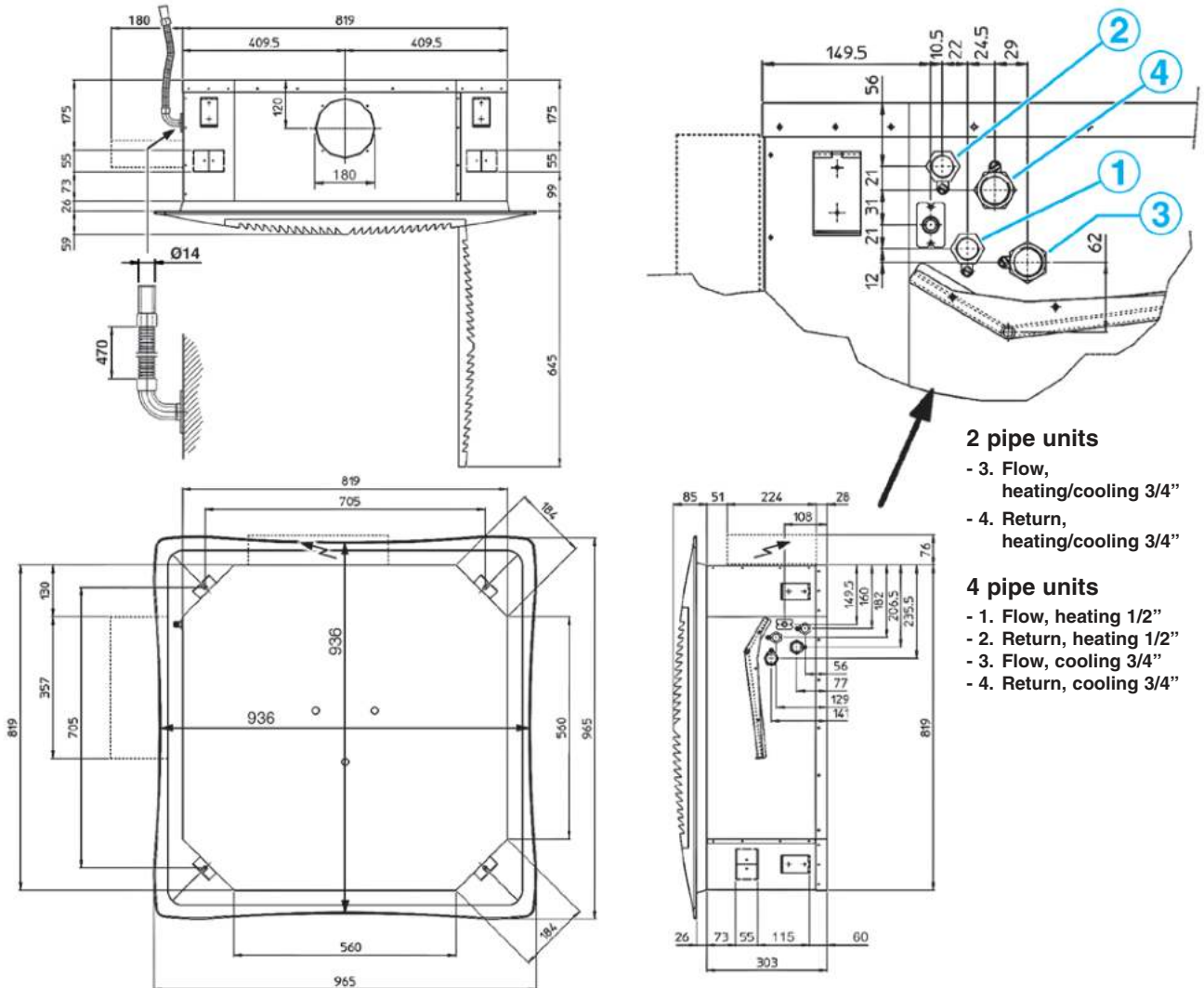

### PACKED UNIT

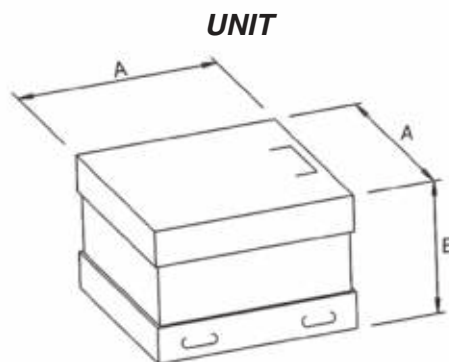

### DIFFUSER

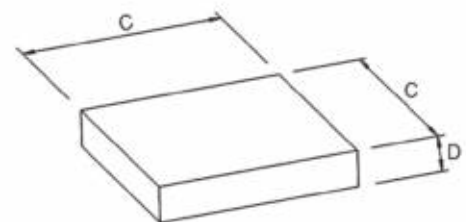

ECM Model	UNIT		DIFFUSER		Packed unit Dimensions			
	Weights packed unit	Weights unpacked unit	Weights packed unit	Weights unpacked unit	A	B	C	D
					mm			
<b>TL 4.2T</b>	kg	kg	kg	kg	1050	400	1000	200
<b>TL 4.4T</b>	44	36	10	6				
<b>TL 5.2T / 5.6T</b>	47	39						

## Air throw

The air throw indicated in the tables must only be considered the maximum value, as it may change significantly in relation to the dimensions of the room in which the appliance is installed and the positioning of the furniture in the room.

The useful throw **L** refers to the distance between the unit and the point where the air speed is 0.2 m/sec; if the louver has a gradient of 30° (recommended in cooling mode), the so-called “Coanda” effect will occur, illustrated in the first figure, while at a gradient of 45° (recommended in heating mode), there will be a downwards throw, as illustrated in the second figure.

### With adjustable air diffusion louvers at 30°

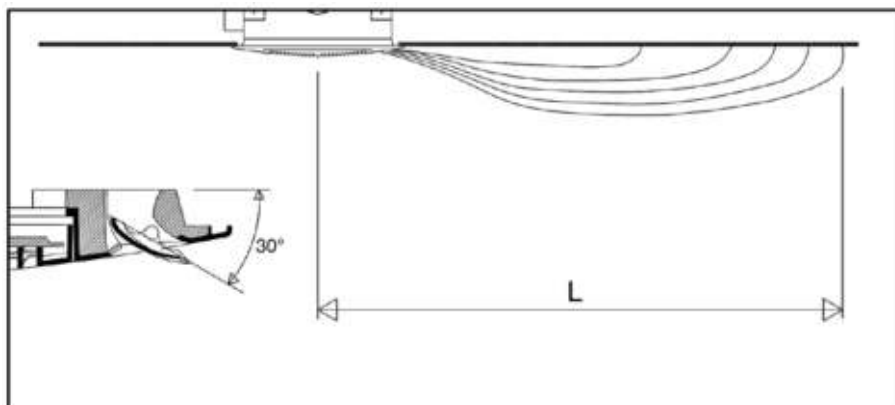

<b>ECM Model</b>		<b>TL 1</b>			<b>TL 2</b>			<b>TL 3</b>			<b>TL 4</b>			<b>TL 5</b>		
Speed		1	2	3	1	2	3	1	2	3	1	2	3	1	2	3
Air throw	<b>L</b> m	3,0	3,5	3,8	3,0	3,8	4,5	3,5	4,2	5,0	3,2	3,7	4,3	3,4	4,0	5,0

### With adjustable air diffusion louvers at 45°

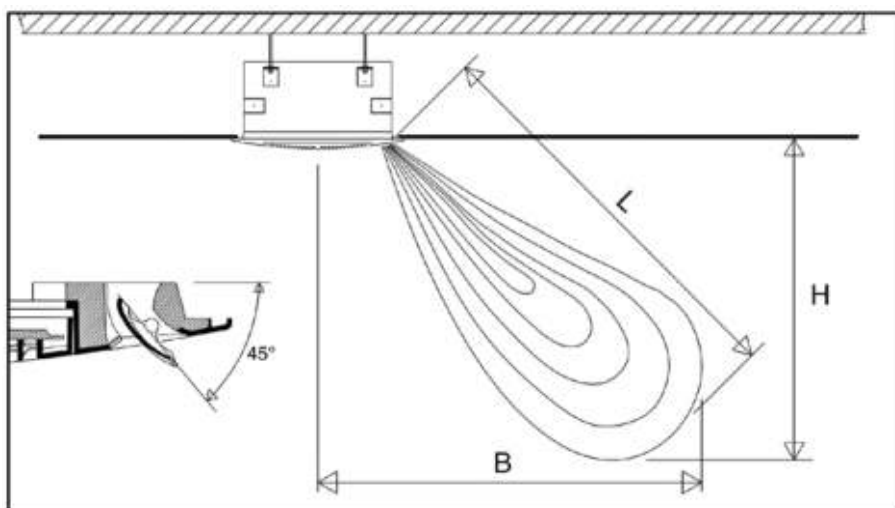

<b>ECM Model</b>		<b>TL 1</b>			<b>TL 2</b>			<b>TL 3</b>			<b>TL 4</b>			<b>TL 5</b>		
Speed		1	2	3	1	2	3	1	2	3	1	2	3	1	2	3
Air throw	<b>L</b> m	3,3	3,9	4,2	3,3	4,2	4,8	3,9	4,5	5,2	3,5	4,1	4,8	3,8	4,6	5,4
Height	<b>H</b> m	2,2	2,6	2,8	2,2	2,8	3,2	2,6	3,0	3,4	2,2	2,6	3,0	2,4	2,8	3,4
Distance	<b>B</b> m	2,5	2,9	3,1	2,5	3,1	3,6	2,9	3,4	3,9	2,7	3,2	3,8	3,0	3,6	4,2

**NOTE:** On heating it must be payed attention to rooms where the floor temperature is particularly low (for example less than 5°C).

In this situation the floor can cool the lower layer of air to a level that stop the uniform diffusion of the hot air coming from the unit, decreasing the throw figures shown in the table.

## Accessories

### Fresh air connection

Only for TL 1-2-3 models  
(not suitable for MCT models with outer casing).

See page 13.

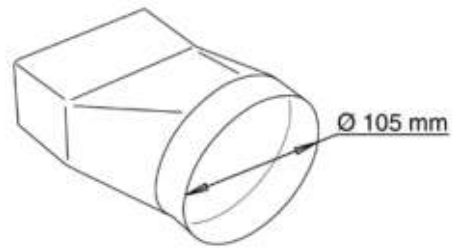

IDENTIFICATION	CODE
CAP	6078005

### Air distribution connection

See page 13.

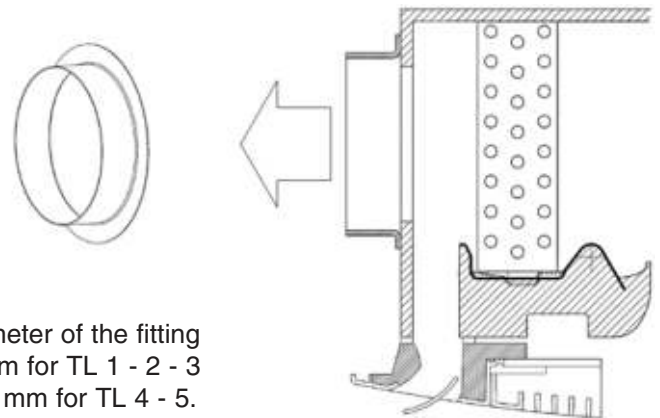

IDENTIFICATION	CODE
CDA 600	9079232
CDA 800	9079233

The diameter of the fitting is 150 mm for TL 1 - 2 - 3 and 180 mm for TL 4 - 5.

### Fresh air kit

This is used to introduce fresh air into the environment directly through the diffuser. The kit includes a flow separator to be fitted inside the cassette, and a circular fitting for connection to the flexible system ducting. The flow of air is sent directly to just one of the outlet louvers, without passing through the coil. The air flow of fresh air introduced into the environment depend on the inlet static pressure.

MODEL	TL 1-2-3	TL 4-5-6
IDENTIFICATION	PRT 600	PRT 800
CODE	9079230	9079231

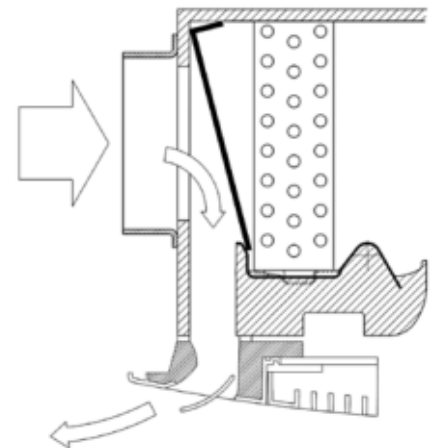

The diameter of the fitting is 150 mm for TL 1 - 2 - 3 and 180 mm for TL 4 - 5.

### Correlation between flow-rate / static pressure

TL 1-2-3		TL 4-5	
m³/h	Pa	m³/h	Pa
80	3	160	3
120	8	200	8
160	15	300	15
200	25	400	25
240	36	500	36

## ON-OFF valves with thermoelectric actuator

### VALVE WITH MICROMETRIC LOCKSHIELD VALVE

**3 ways**



TL 1.2-1.4  
TL 2.2-2.6  
TL 3.2-3.6

TL 4.2-4.4  
TL 5.2-5.6

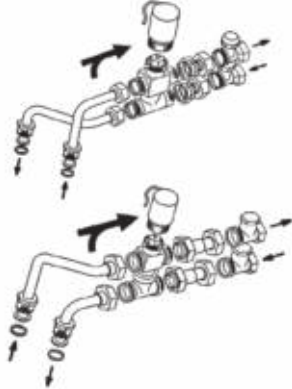

**2 ways**



TL 1.2-1.4  
TL 2.2-2.6  
TL 3.2-3.6

TL 4.2-4.4  
TL 5.2-5.6

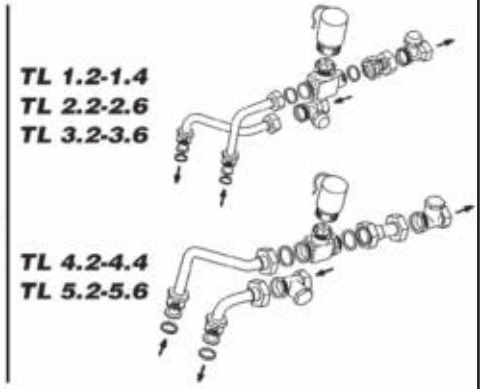

### VALVE WITH SIMPLIFIED KIT

**3 ways**



TL 1.2-1.4  
TL 2.2-2.6  
TL 3.2-3.6

TL 4.2-4.4  
TL 5.2-5.6

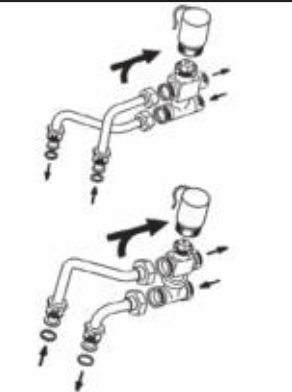

**2 ways**



TL 1.2-1.4  
TL 2.2-2.6  
TL 3.2-3.6

TL 4.2-4.4  
TL 5.2-5.6

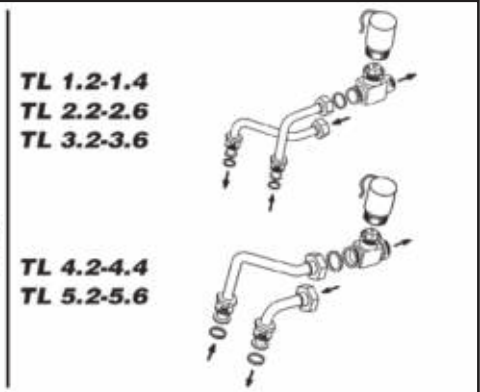

#### Technical data:

Rated pressure:	16 bar
Max. ambient temperature:	50 °C
Max. water flow temperature:	110 °C
Power:	230 V - 50/60 Hz
Rating:	3 VA
Protection:	IP 43
Travel time:	approx. 3 min.
Max. glycol content of water:	50%

#### Valves characteristics

Battery type	ECM Model	2 way valves			3 way valves		
		Kvs m <sup>3</sup> /h	Δp <sub>max</sub> kPa *	Valve ** connection	Kvs m <sup>3</sup> /h	Δp <sub>max</sub> kPa *	Valve ** connection
Main	<b>1.2/2.2/3.2</b>	2,8	50	3/4"	2,5	50	3/4"
	<b>1.4/2.6/3.6</b>						
	<b>4.2/5.2</b> <b>4.4/5.6</b>	5,2	60	1"	4,5	50	1"
Auxiliary	<b>1.4/2.6/3.6</b>	2,8	50	3/4"	2,5	50	3/4"
	<b>4.4/5.6</b>						

\* maximum pressure difference for valve to close    \*\* external thread, flat seal  
**Note:** 3 way valves with simplified kit and 1" connection have conical seal.

#### Valves pressure drop

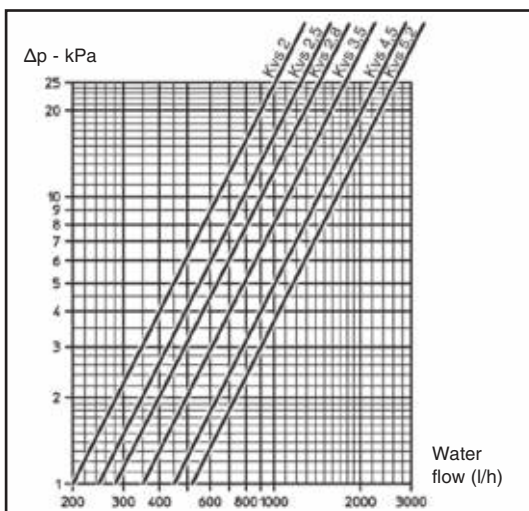

Valve set, 2 or 3 ways, ON-OFF, with thermoelectric actuator. The set includes connection pipes.

**Note:** The main battery lockshield valve connection is 1/2" female (Kvs 2) for TL1 - TL2 - TL3 sizes and 3/4" female (Kvs 3,5) for TL4 - TL5 sizes, the auxiliary battery valve connection is 1/2" female (Kvs 2).

**Note:** The maximum pressure drop across the fully open valve should not exceed 25 kPa for cooling operation and 15 kPa for heating operation.

For 2 way balance valve, refer to page 16.

### TL-ECM configuration

For this cassette configuration, the 1-10 Vdc signal, which controls the inverter, must be supplied by a controller with the following signal specifications:

#### Fan Drive Signal

- 0 Vdc = Fan OFF
- >1 Vdc = Fan ON
- 10 Vdc = Maximum speed

#### ECM BLAC Board

0÷10 Vdc Circuit Input Impedance Value = 68kOhm

### TL-ECM electric diagram

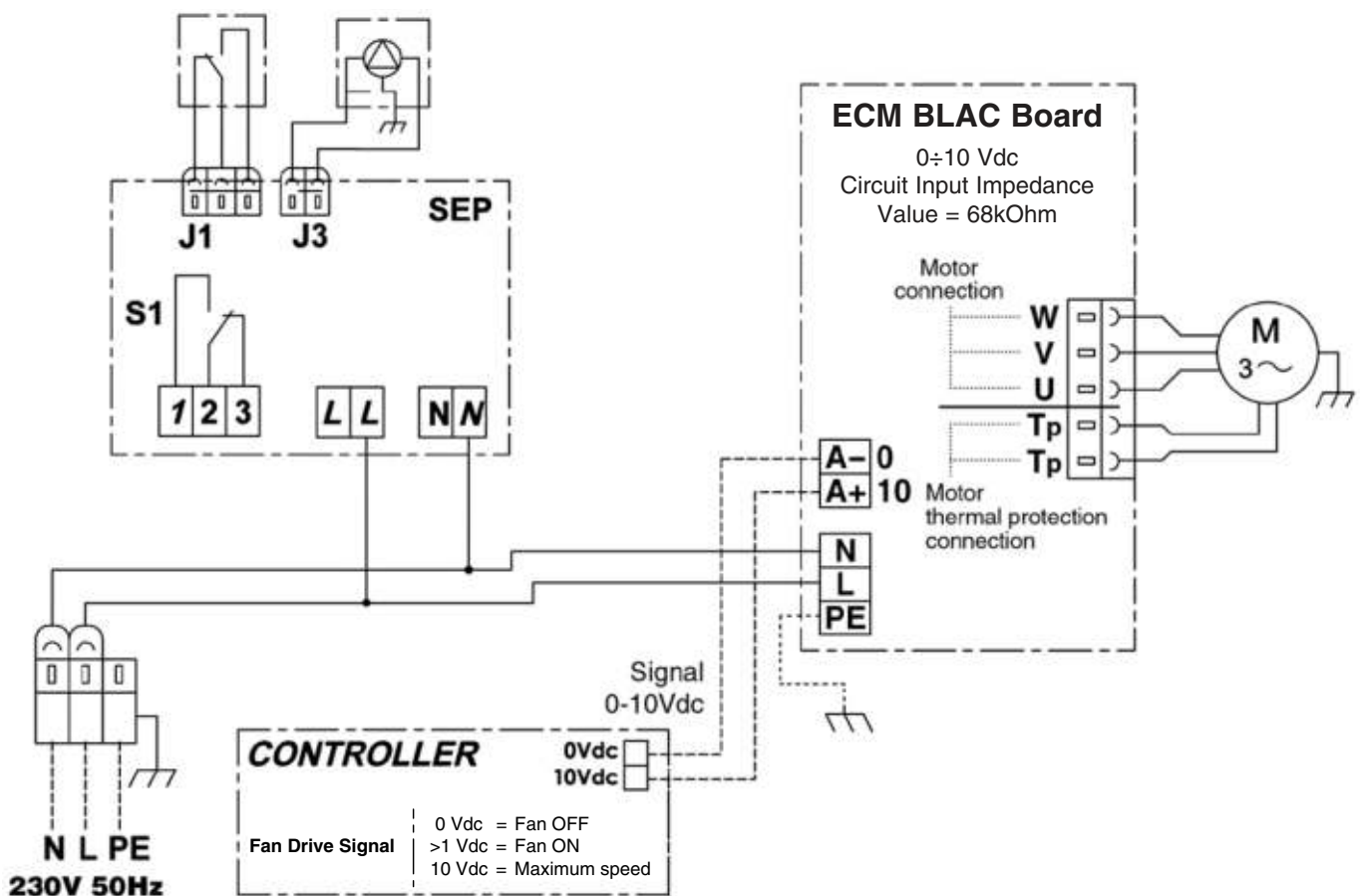

#### LEGEND

- SEP = Pump control board
- BLAC = Inverter board
- M = Electronic motor
- CONTROLLER = Controller

## Wall electronic controls

IDENTIFICATION	CODE
WM-AU	9066632E



Dimensions: 135x86x24 mm

**The control must always be connected with UPM-AU power unit (fitted on the unit) or with UP-AU power unit (not fitted on the unit).**

- ON-OFF switch
- Manual or automatic 3 speed progressive switch.
- Manual, automatic or centralized Summer/Winter switch.
- Summer/Winter/Fan/Auto mode switch.
- Electric heater/IAQ filter activation switch.
- Electronic room thermostat for fan and water valves control (ON-OFF).
- Simultaneous thermostatic control of the valves and fan.
- It allows to use the low temperature cut-out thermostat (NTC) mounted on the UP-AU power unit.
- It allows to control the water valves (ON-OFF) and the electric heater managed as main heating element or as an integration element.
- Energy saving switch
- Presence of a LED signal when the thermostat is on.

**N.B.:** with 4 pipe installations and continuous chilled and hot water supply, it allows the automatic summer winter change-over in accordance to the room temperature (-1°C = Winter, +1°C = Summer, Neutral Zone 2°C).

Control power absorption: see the UP-AU power unit

IDENTIFICATION	CODE
T-MB	9066631E



Dimensions: 110x72x25 mm

**The control must always be connected with UPM-AU power unit (fitted on the unit) or with UP-AU power unit (not fitted on the unit).**

Wall control with display that allows controlling one or more units in Master/Slave mode. The control is equipped with internal sensor to detect the room temperature, which can be defined as a priority compared to the return air sensor on the fan coil.

The T-MB control features the following functions:

- Switch the unit ON and OFF
- Temperature set.
- Manual, automatic or centralized Summer/Winter switch.
- Set the fan speed (low, medium, high or autofan).
- Set the operation mode (fan only, cooling, heating; auto for 4 pipe systems with mode selection depending on the air temperature).
- Possibility of use of the low temperature cut-out thermostat NTC mounted on the UP-AU power unit.
- It allows to control the water valves (ON-OFF) and the electric heater managed as main heating element or as an integration element.
- Time setting
- Weekly ON/OFF program.

Control power absorption: see the UP-AU power unit

IDENTIFICATION	CODE
WM-S-ECM	9066644



Dimensions: 132x87x23,6 mm

0-10V control with display designed to be mounted on the wall or to be installed on a 503 wall box.

- ON-OFF switch.
- Manual 3 speed switch or automatic continuous speed control.
- Summer/Winter switch.
- Summer/Winter/Fan/Auto mode switch.
- Electronic room thermostat for fan control (ON-OFF).
- Electronic room thermostat for valve control (ON-OFF).
- Simultaneous thermostatic control of the valves and fan.
- It allows to control the low temperature cut-out thermostat (NTC).

Control power absorption: 1,2 VA

## Wall electronic controls

DESCRIPTION	IDENTIFICATION	CODE
Power unit for WM-AU and T-MB remote control (fitted on the unit)	UPM-AU	9066641
Power unit for WM-AU and T-MB remote control (not fitted on the unit)	UP-AU	9066640



Power unit to be installed on the fan coil (fan coil interface).

- It controls the fan and the valves of the fan coil.
- It is connected to the electric supply.
- It receives the information required from the control.
- Possibility to use the low temperature cut-out thermostat (optional) for the T1 function which allows the return air control.
- Possibility to use the low temperature cut-out thermostat (optional) for the T2 function which controls the summer/winter switch.
- Possibility to use the low temperature cut-out thermostat (optional) for the T3 function as low temperature cut-out thermostat.
- It allows to control up to 10 units (1 master and 9 slaves).
- Max. Network length: 100 meters.
- Max cable length between control and first connected power unit: 20 meters.

Control power absorption: 2,3 VA

## Wall electronic controls accessories

### NTC low temperature cut-out thermostat

To be fitted between the coil fins.

When connecting the control, the NTC probe cable must be separated from the power supply wires.

To be used with WM-S-ECM control and UP-AU power unit.

It stops the fan when the water temperature is lower than 28°C and it starts the fan when is higher than 33°C.

To use as:

- T1 function for the return air control.
- T2 function which controls the summer/winter switch.
- T3 function as low temperature cut-out thermostat.

IDENTIFICATION	CODE
NTC	3021090



### T2 sensor

T2 sensor to be placed on the water supply pipe upstream 3 way valves (not to be used with 2 way valve).

The T2 sensor must be used as described below:

- Change-Over for the automatic switch of the operating mode. If water temperature is lower than 20°C, cooling mode is set; on the other hand, if water temperature exceeds 30°C, heating mode is set.

To be used with UP-AU power unit.

IDENTIFICATION	CODE
T2	9025310

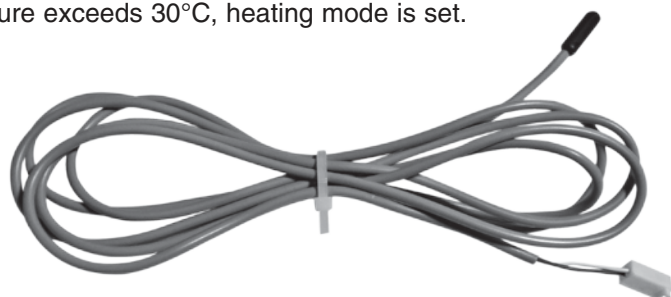

## Controls for TL-ECM-MB versions

All the **TopLine ECM** units can be supplied in **MB version**. This version includes a wide range of controls, including the **infra-red remote control**, which allows managing one single unit or several units by using the **Modbus RTU - RS 485** communication protocol.

Units can be managed according to the Master/Slave logic (up to 20 units) or by supervisory components.

The system consists in a **MB board** (mounted on models **TL-MB** and **TL-ECM-MB**) and a series of controls, such as the **T-MB** wall control, the **RT03** infra-red remote control, the **PSM-DI** multifunction control and the **NET** supervisory program.



**T-MB wall control**

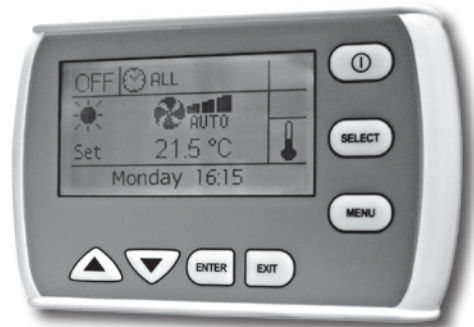

**PSM-DI multifunction control**



**RT03 infra-red remote control**

**NET screenshot**

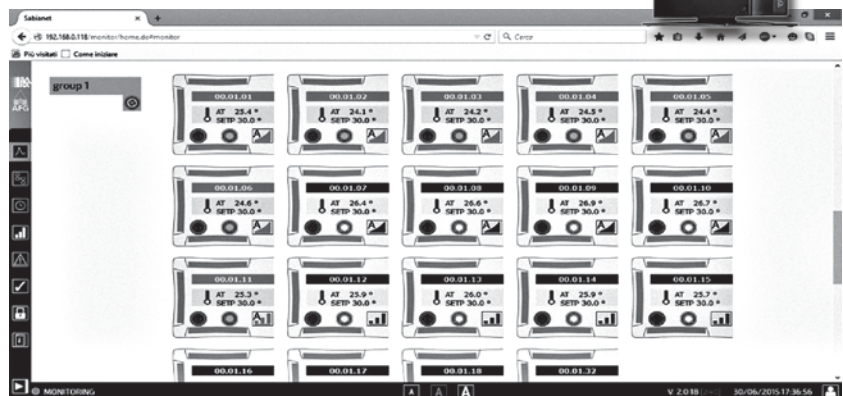

**PC**

**NET software**

All the controls and their functions are described in detail from Page 50.



## Electric heater TL-ECM-E

The Cassette 2 pipe models are available with electric resistance that is controlled in place of the heating battery valve. The electric resistance is controlled in place of the hot water valve and not as integration to it. The resistance is hermetically sealed and supplied inside the battery pipes and therefore can be only factory mounted. The electric resistances of the units are for single phase 230V supply. The Cassette includes no. 2 safety thermostats which intervene in case of internal over- heating, opening an auxiliary power relay (included in the shunt box) which stops the power supply to the resistances.

ECM Model	TL 1.2T-E	TL 2.2T-E / TL 3.2T-E	TL 4.2T-E / TL 5.2T-E / TL 6.2T-E
Emission	1500 Watt	2500 Watt	3000 Watt
Supply	230V ~	230V ~	230V ~
Number and Dia. of connecting wires	3 x 1,5 mm <sup>2</sup>	3 x 2,5 mm <sup>2</sup>	3 x 2,5 mm <sup>2</sup>

Note: the cooling emission of the units is 95% of the emission in the tables of page 34.

## Electric diagram

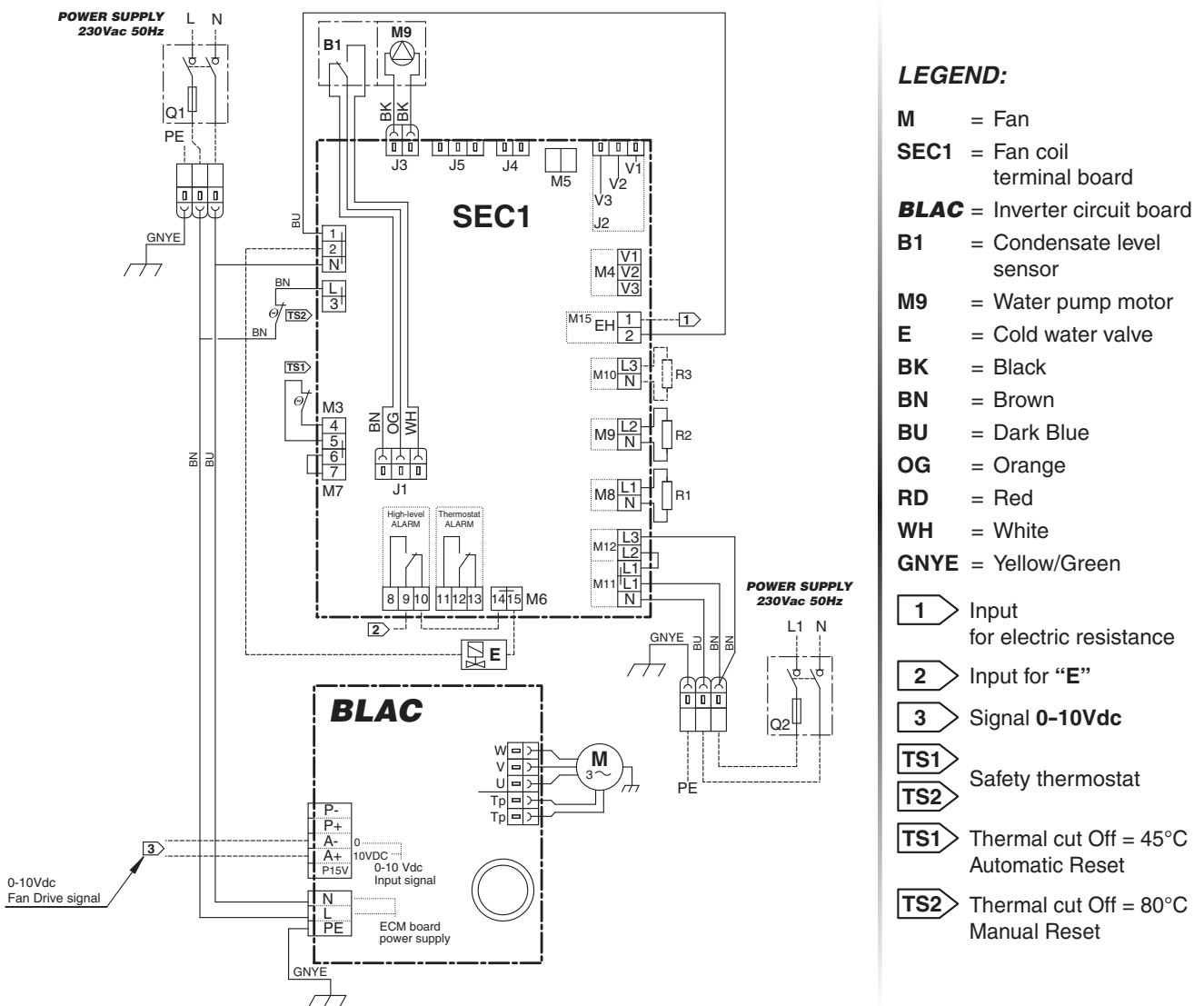

## Cassette unit operating limits with electric coil

Max. ambient temperature for Cassette unit with electric coil in heating mode: 25°C

## MB controls

### MB electronic board

The **MB** electronic board, mounted as per standard on the TL-MB and TL-ECM-MB versions, is set to carry out different functions and adjustment modes, in order to meet the installation requirements. These modes are selected by setting the configuration dip switches on the board.

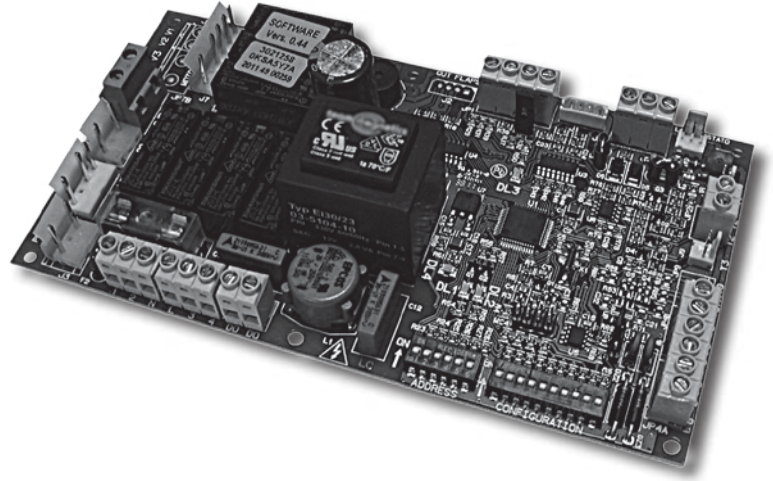

- 2/4 pipe system.
- Fan ON/OFF thermostatic control.
- Valve ON/OFF thermostatic control and continuous ventilation.
- Valve and simultaneous ventilation ON/OFF thermostatic control.
- Fan operation control depending on the coil temperature (cut-out T3 probe fitted), which can be activated only in heating mode or heating and cooling mode.
- Automatic switch of the operating mode by means of T2 water probe (optional) applied on the 2 pipe system.
- Seasonal switch by means of remote contact.
- ON/OFF of the fan coil by means of the remote contact (window or clock contact).
- Electric heater control or electronic filter control (the simultaneous control of the heater and of the filter is not possible).

By activating the cut-out T3 probe function, the fan is stopped in winter when the coil temperature is lower than 32°C and started when the temperature reaches 36°C. In summer mode, the fan stops when the temperature inside the coil exceeds 22°C and starts when it drops below 18°C.

The following connections are located on the power board:

- Receiver for infra-red remote control.
- T-MB wall control.
- RS 485 serial connection to manage several fan coils in Master/Slave configuration or to create a supervisory network.

**MB controls**

**T-MB wall control**

DESCRIPTION	IDENTIFICATION	CODE
Wall control (to be used with TL-MB and TL-ECM-MB version only)	T-MB	9066331E

Wall control with display that allows controlling one or more units in Master/Slave mode. The control is equipped with internal sensor to detect the room temperature, which can be defined as a priority compared to the return air sensor on the fan coil.

The **T-MB** control features the following functions:

- Switch the appliance ON and OFF.
- Temperature set.
- Modify the set point (when used as a +/- 3° variation of the set point configured from NET supervisory program or PSM-DI).
- Set the fan speed (low, medium, high or autofan).
- Set the operation mode (fan only, cooling, heating; auto for 4 pipe systems with mode selection depending on the air temperature).
- Time setting.
- Weekly ON/OFF program.
- Display and change of the fan coil operation parameters.



Dimensions: 110x72x25 mm

**MB controls**

**RT03 infra-red remote control**

DESCRIPTION	IDENTIFICATION	CODE
RT03 infra-red remote control with receiver supplied with separate packaging (to be used with TL-MB and TL-ECM-MB version)	RCS-RT03	9079117
Receiver for RT03 infra-red remote control supplied with separate packaging (to be used with TL-MB and TL-ECM-MB version)	RCS	9079116
Receiver for RT03 infra-red remote control and MD-600/MD-800 metal diffuser supplied with separate packaging (to be used with TL-MB and TL-ECM-MB version only)	RS	9066338
RT03 infra-red remote control supplied with separate packaging (to be used with TL-MB and TL-ECM-MB version)	RT03	3021203

The infra-red remote control allows setting by a remote position the fan coil operation parameters.

The **RT03** infra-red remote control features the following functions:

- Switch the appliance ON and OFF.
- Temperature set.
- Set the fan speed (low, medium, high or autofan).
- Set the operation mode (fan only, cooling, heating; auto for 4 pipe systems with mode selection depending on the air temperature).
- Time setting.
- 24 hours ON/OFF program.



IDENTIFICATION	CODE
RT03	3021203

**INSTALLATION EXAMPLE  
WITH INFRA-RED REMOTE CONTROL**



IDENTIFICATION	CODE
RCS-RT03	9079117



IDENTIFICATION	CODE
RCS	9079116

## MB controls

A group of **TopLine MB** can be connected via a serial link and can consequently be managed at the same time by just one **T-MB** wall control or **RT03** infra-red remote control. Using the special jumper present on the **MB** board, one unit must be configured as the master, and all the others as slaves. It is clear that the remote control must be pointed at the receiver on the master unit. To avoid problems, it is recommended to install and connect the receiver only on the master unit.

### With T-MB wall control

**One control for each cassette**  
(MAXIMUM LENGTH OF THE CONNECTION CABLE = 20 m)



**One control for more cassettes (20 units max.)**  
(MAXIMUM TOTAL LENGTH OF THE CONNECTION CABLE = 800 m)

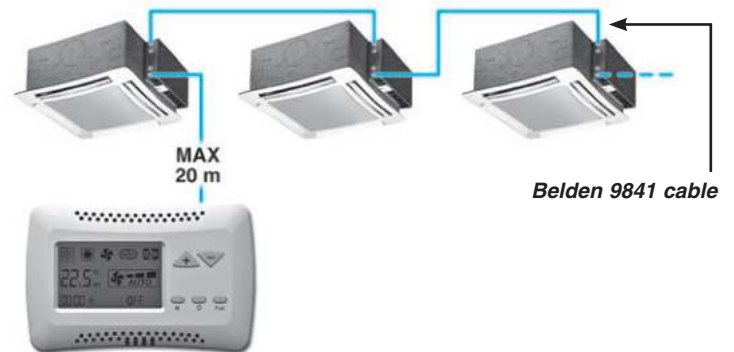

### With RT03 infra-red remote control

**One control for each cassette**



**One control for more cassettes (20 units max.)**  
(MAXIMUM TOTAL LENGTH OF THE CONNECTION CABLE = 800 m)

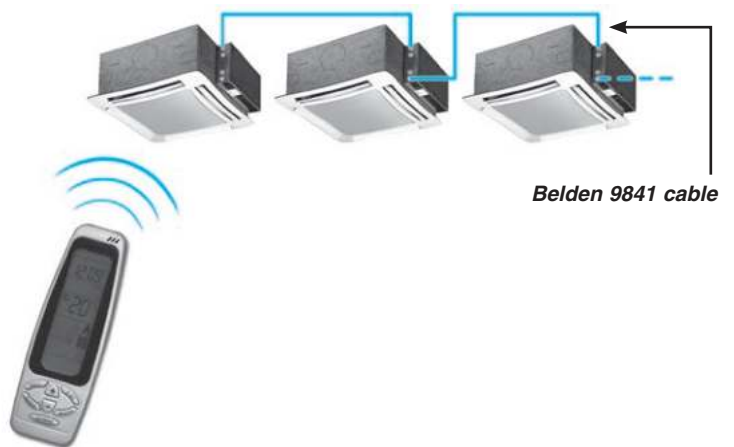

## T2 accessory for units with MB electronic board

IDENTIFICATION	CODE
T2	9025310

The T2 sensor can be combined with MB boards to be placed on the water supply pipe upstream 3 way valves (not to be used with 2 way valve).

The T2 sensor must be used as described below:

- Change-Over for 2-pipe system for the automatic switch of the operating mode.  
If water temperature is lower than 20°C, cooling mode is set; on the other hand, if water temperature exceeds 30°C, heating mode is set.

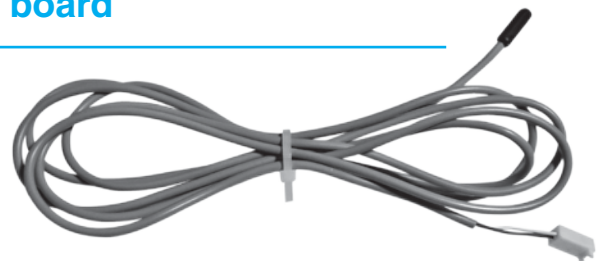

## MB controls

### PSM-DI multifunction control panel

DESCRIPTION	IDENTIFICATION	CODE
Multifunction control (to be used with TL-MB and TL-ECM-MB version only)	PSM-DI	3021293

Another option available for the serial communication between the units is the possibility to connect up to 60 **Cassette** units in series and manage them with just one wall mounted **PSM-DI** controller. The wall mounted controller can be used to set the operating mode for each individual unit connected, display the operating conditions of each individual unit, and set the ON/OFF time sets for each day of the week (the program can be set for all the units and for a maximum of ten groups of units).

If more than 60 units need to be connected, two or more control panels must be used. Each unit must have a MB board. The **PSM-DI** control is used to manage a series of fan coils, up to a maximum of 60 units (the maximum length of the RS 485 connection cable must not exceed 800 m), from one single control point.

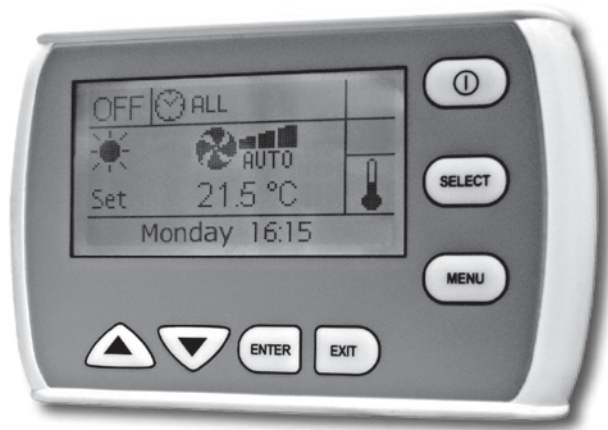

The **PSM-DI** control communicates via a serial line with all the units connected, with the possibility of controlling them all together or individually. In fact, the unique address of each individual fan coil means that all the units can be called at the same time, or the individual unit called, to perform the following functions:

- display the current operating mode, the fan speed, the set point;
- display the room temperature measured on the individual unit;
- turn all the units ON and OFF at the same time or alternatively each unit individually;
- change the operating mode (fan only, heating, cooling, automatic changeover);
- change the set point;
- modify the values and operation parameters of the fan speed.

Each function can then be sent to all the units connected, or alternatively to each individual unit.

Different set points or operating modes can be set for each individual unit.

The **PSM-DI** panel can also be used for the time management of the units over the week. Four ON times and four OFF times can be set on the units for each day of the week. A different temperature set that will be considered as Operation set for all connected appliances, can be set for each event. If the temperature set is not entered for the individual event, it must be set during programming for each individual unit or for the entire network.

Units without receiver or with receiver can be connected within the network: the former can receive instructions only from the **PSM-DI** wall mounted panel; while the latter can receive information from both the wall mounted panel (**PSM-DI**) and infra-red remote control. Use the infra-red remote control to force ON mode of the individual unit, if ON/OFF daily time programming has been set. The unit will regain the settings from the **PSM-DI** panel during execution of successive start-up program.

***The PSM-DI panel cannot be used together with the NET management program (see next page).***

**Notes:**

- set the Dip Switches of each fan coil as illustrated in the remote control installation manual, based on the required solutions.
- it is possible to connect only one single SIOS board per each PSM-DI control panel.
- about "Priority pump function": when just one unit calls for, the relay RL1 on the SIOS board is automatically activated to connect a hot water pump.
- the RS 485 network's overall length must not exceed 700/800 metres.

## Management system for a network of fan coils

### ***NET program for managing a network of MB fan coils***

DESCRIPTION	IDENTIFICATION	CODE
Hardware/software supervisory system (to be used with with TL-MB and TL-ECM-MB version only)	NET	9079118

**NET** is a centralised control system for networks of MB fan coils, based on software that runs on LINUX™ operating system (the program is provided pre-installed on a PC) and it works in a “stand alone” way, as an ordinary computer, so that it can be connected to a monitor, to a mouse and to a keyboard. By connecting an Ethernet cable is instead possible to work at a distance and visualize the entire program setting-up through whatever browsers. The **NET** software offers a practical and economical solution for managing the units, with the simple click of the mouse.

The main characteristics include:

- simplicity of use;
- an extremely complete and functional weekly program;
- possibility to access the historical operating data for each individual unit connected;
- possibility to save automatically every 6 h the data on SD support and to force the saving with a switch;
- possibility of data saving also on other items, as for example USB keys;
- visualization of the saved configuration on a new ASUS PC.



The program exploits all the potential of our units with remote controls, representing an addition to the latter.

The **NET** program is a control tool that can be used as a replacement for the remote control, or in parallel, however the settings made using **NET** can have priority over those made using the remote control or T-MB.

The program can be used to:

- Create uniform groups (groups of units on individual floors, in offices or rooms).
- Save weekly programs configured for different types of operation (summer, winter, mid seasons, closing periods etc.); these can then be recalled and activated with a simple click of the mouse. Weekly on/off cycles can be set for individual units or groups of units.
- Set the operating conditions for each individual unit or groups of units (operating mode, fan speed, temperature setting).
- Set the set point limits for each individual unit or groups of units.
- Switch each individual unit or groups of units ON or OFF.

## Management system for a network of fan coils

The main program screen can display and interact with the entire network of units. An individual unit, a group of units or the entire network can be called so as to make modifications to the operating mode and the set point. The user can then check the operating status of each individual unit, read the room temperature, the coil temperature and the operating status of the condensate drain pump or any alarms.

"MONITORING" SCREEN



### Displaying a unit

The "MONITORING" SCREEN shows the units that are connected to the network and scanned by the program.

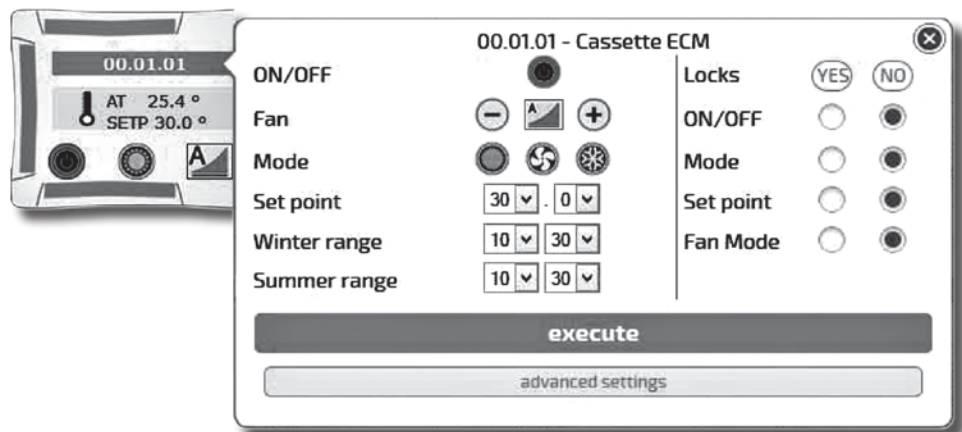

The icon of the terminal unit provides the following information:

- Unit name (**00.01.01**)
- Set temperature (SETP)
- Room temperature (AT)
- Unit status: ON (Green) or OFF (Red)
- Mode:
  - Summer
  - Auto
  - Winter
  - Fan only
- Fan speed:
  - Low
  - High
  - Medium
  - AutoFan



## Management system for a network of fan coils

The “Weekly Program” can be used to set the unit operating parameters for each day of the week. Several weekly programs can be set.

“EVENT MANAGEMENT” SCREEN

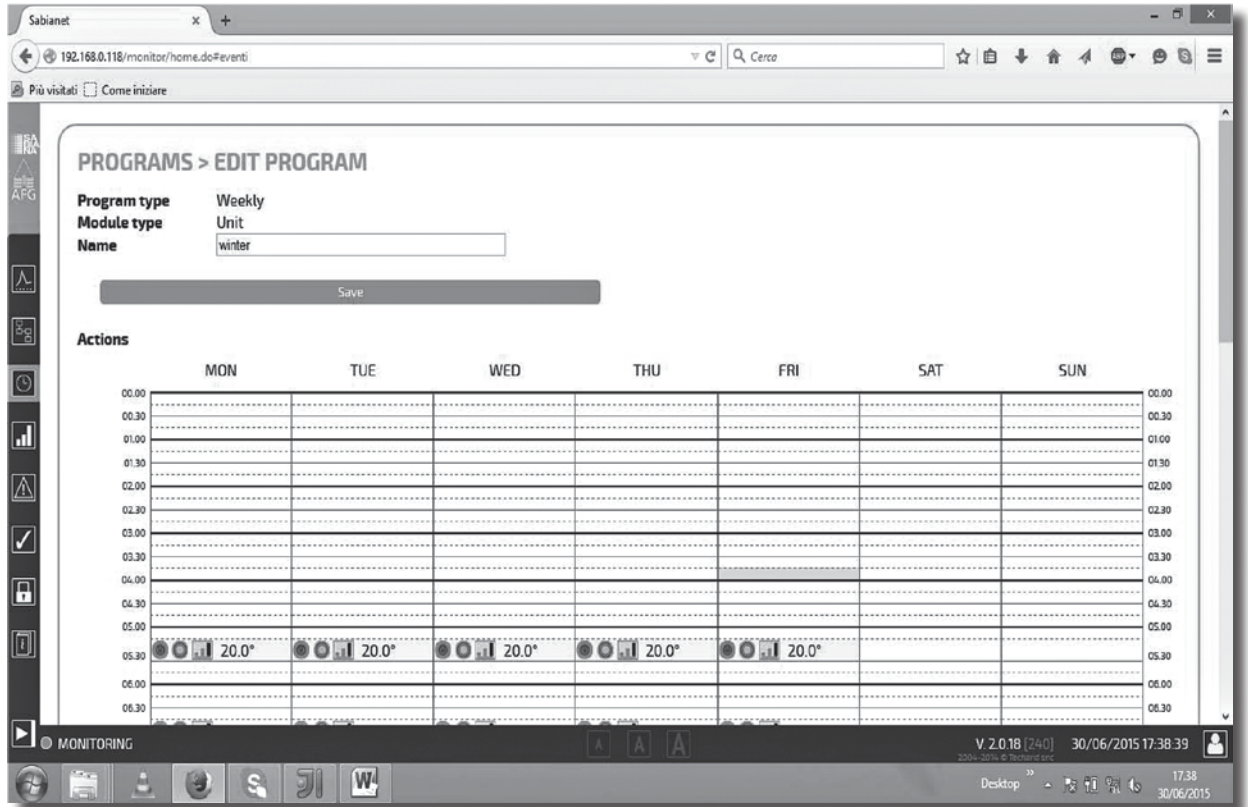

Time bands are available for each day of the week. The time and the type of operation to be performed by the unit can be set for each band. The time and the operating parameters can then be displayed before being sent to the unit and implemented.

### Displaying of the parameters and Dip Switches set up

Every time that the reading of the set up Dip Switches results not easy (as for example by the false ceiling installations), it is always possible to display them directly through the NET program.

<b>Group:</b> gruppo 1	<b>FW release:</b> 0.50	<b>Program:</b> gruppo 1 inverno	
<b>Remote control:</b> N.A.	<b>M/S network:</b> N.A.	<b>Unit tree:</b> Level 2 --> Router 1	
<b>Unit status:</b> ON	<b>Mode:</b> WINTER	<b>Fan mode:</b> AUTO	<b>Fan status:</b> OFF
<b>Set Point:</b> 22.0°	<b>Heating status:</b> OFF	<b>Cooling status:</b> [OFF]	<b>Inverter voltage:</b> 0.2
<b>T1:</b> 22.5°	<b>T2:</b> N.A.	<b>T3:</b> 28.5°	
<b>Pump:</b> YES	<b>Remote ON/OFF input:</b> OFF	<b>Window input:</b> OFF	

Unit settings		Alarms
<b>Dip Switch:</b>	OFF ON	
<input type="checkbox"/>	1 2 pipe unit	<b>T1 Fault</b> OFF
<input type="checkbox"/>	2 Thermal station with valves	<b>T2 Fault</b> OFF
<input type="checkbox"/>	3 T3 disabled	<b>T3 Fault</b> OFF
<input type="checkbox"/>	4 T3 only winter when enabled	
<input type="checkbox"/>	5 Simultaneous ventilation of valves	<b>Condensation</b> OFF
<input type="checkbox"/>	6 Unit without electrical heater	
<input type="checkbox"/>	7 T2 as CH Change-over (resistance phase II)	
<input type="checkbox"/>	8 UNIT ALERT	
<input type="checkbox"/>	9 Remote ON/OFF input	
<input type="checkbox"/>	10 MASTER	

## Management system for a network of fan coils

### Alarm control by E-mail and sms

In addition to the alarm set on the NT display, it is possible to send the ON-OFF alarm notification via E-mail and sms.

#### ALARMS

##### Ongoing alarms

At	Address	Unit name	Group	Alarm type
No alarms				

##### Alarms log

From	To	Address	Unit name	Group	Alarm type
No alarms					

##### Notification

Event type	eMail						SMS					
	none	instant	after 1 hour	after 3 hours	after 6 hours	at the end	none	instant	after 1 hour	after 3 hours	after 6 hours	at the end
Alarm on unit [any]	<input checked="" type="radio"/>	<input type="radio"/>	<input type="radio"/>	<input type="radio"/>	<input type="radio"/>	<input type="checkbox"/>	<input checked="" type="radio"/>	<input type="radio"/>	<input type="radio"/>	<input type="radio"/>	<input type="radio"/>	<input type="checkbox"/>
Condensate alarm on unit	<input checked="" type="radio"/>	<input type="radio"/>	<input type="radio"/>	<input type="radio"/>	<input type="radio"/>	<input type="checkbox"/>	<input checked="" type="radio"/>	<input type="radio"/>	<input type="radio"/>	<input type="radio"/>	<input type="radio"/>	<input type="checkbox"/>
Probe alarm on unit	<input checked="" type="radio"/>	<input type="radio"/>	<input type="radio"/>	<input type="radio"/>	<input type="radio"/>	<input type="checkbox"/>	<input checked="" type="radio"/>	<input type="radio"/>	<input type="radio"/>	<input type="radio"/>	<input type="radio"/>	<input type="checkbox"/>

Save

### RS 485 serial connection cable

Shielded cable to be used:

Belden 9841, RS-485, 1x2x24 AWG SFTP, 120 Ohm



### PC NET Software

Connection of a **Cassette TopLine TL-MB** or **TL-ECM-MB** network

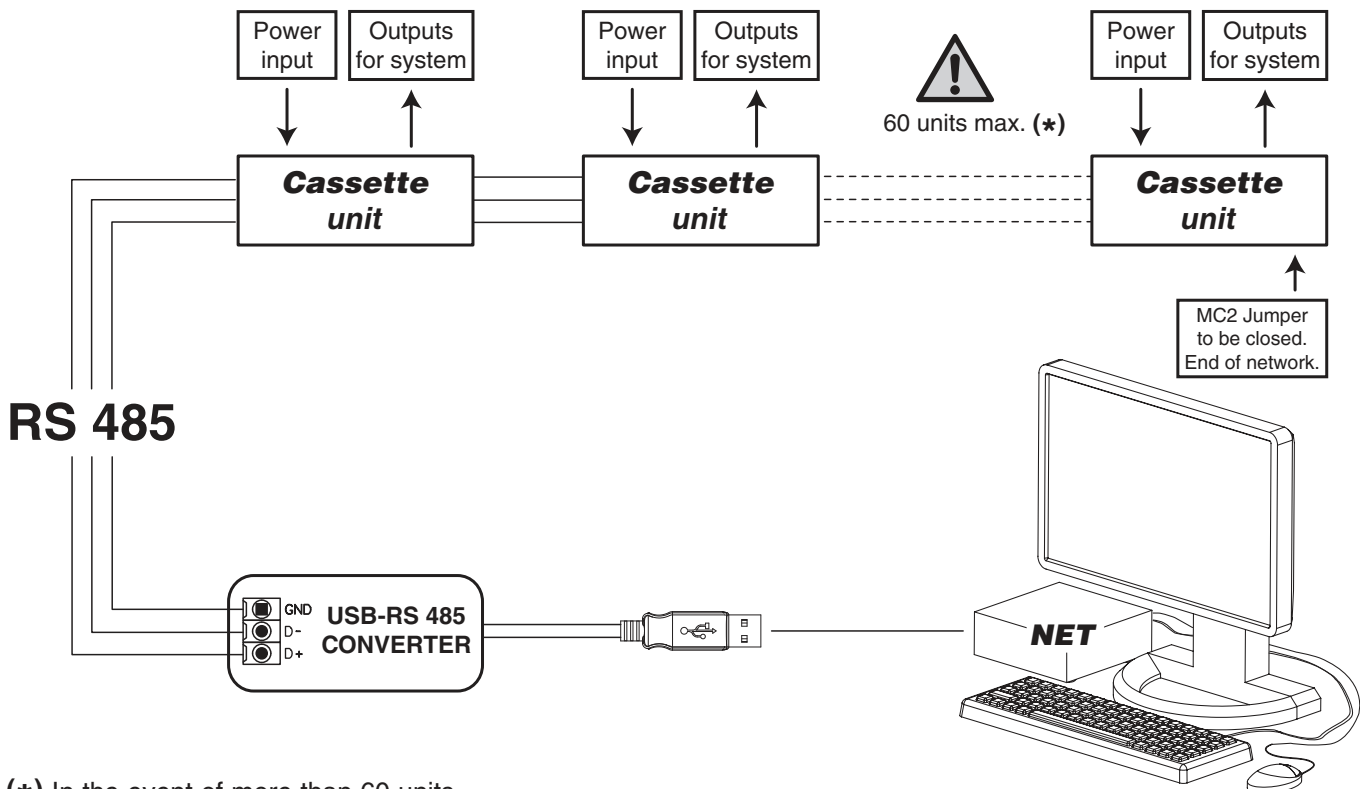

(\*) In the event of more than 60 units, add one or more Router-S (see next page).

## PSM-DI and NET accessories

IDENTIFICATION	CODE
SIOS	3021292

SIOS is a board equipped with 8 relays with potential free contact to control the activation or deactivation of remote electric utilities. Moreover, the board has 8 digital inlets to display the actuators or external consents, such as motor or other.

The SIOS boards can be connected:

- inside a network managed by NET;
- to a PSM-DI panel (one SIOS for each PSM-DI panel).

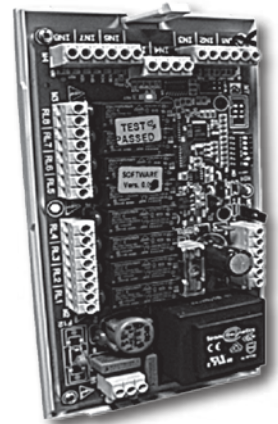

IDENTIFICATION	CODE
Router-S	3021290

The Router-S is an electronic board that allows to control several units inside a network managed by NET (default) or within a sub-network managed by BMS systems, that are not provided by us (it is necessary to operate on a Dip Switch on the board).

### Managed by NET

The Router-S in the standard version is an electronic board that:

- allows creating networks with more than 60 units (minimum 2 Router-S are required) or to divide the network (per floor, building, etc.);
- it allows creating a Master/Slave sub-network to be controlled as an independent group.

The Router-S in the standard version can be used only inside a network managed by NET. The number of Router-S to be used is:

- up to 60 units: no Router-S
- from 61 to 120 units: 2 Router-S
- every 60 subsequent units: 1 additional Router-S

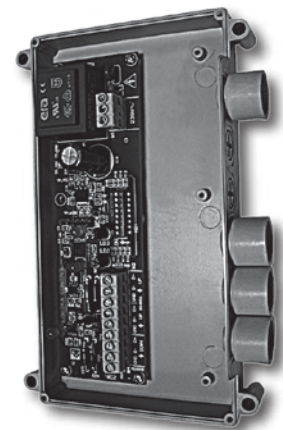

### Managed by BMS Systems which are not provided by us

The Router-S becomes an electronic board to use with BMS systems not supplied by us, only after having set the Dip Switch on the board and so creating a Master/Slave sub-network to be controlled as an independent group.

The number of Router-S to use is:

- maximum 14 Router-S.
- maximum 15 fan coils per Router-S.

## Introduction

The MCT version has been designed for all environments where false ceilings are not featured or cannot be constructed.

The cover cabinet fits perfectly to the air intake and outlet diffuser, maintaining the appealing design that defines the TopLine series. The water fittings can be turned to point upwards.

The MCT series includes 7 models, with an installation height of up to 5 m, thanks to the highly flexible adjustment of the air distribution louvers.

All the technical specifications described on the previous pages remain the same, while keeping in mind that:

- the MCT series features one coil only (two pipe systems)
- there is no possibility of fresh air intake
- there is no possibility of additional electric heater

The MCT version features a special casing delivered in separate packaging; this must only be fitted after having installed the TopLine unit and completed the water and electrical connections.



## Dimensions and Weights

### TL 0.2-MCT / TL 1.2-MCT / TL 2.2-MCT / TL 3.2-MCT

Casing code: 9079240

Casing weight: 5 kg (7,5 kg with the packaging)

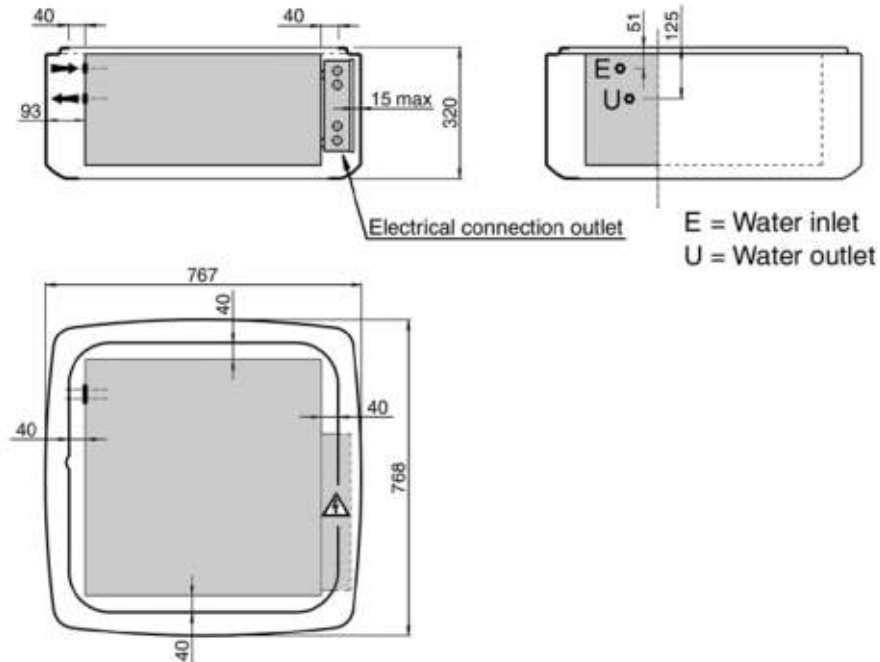

### TL 4.2-MCT / TL 5.2-MCT / TL 6.2-MCT

Casing code: 9079250

Casing weight: 10,5 kg (13,5 kg with the packaging)

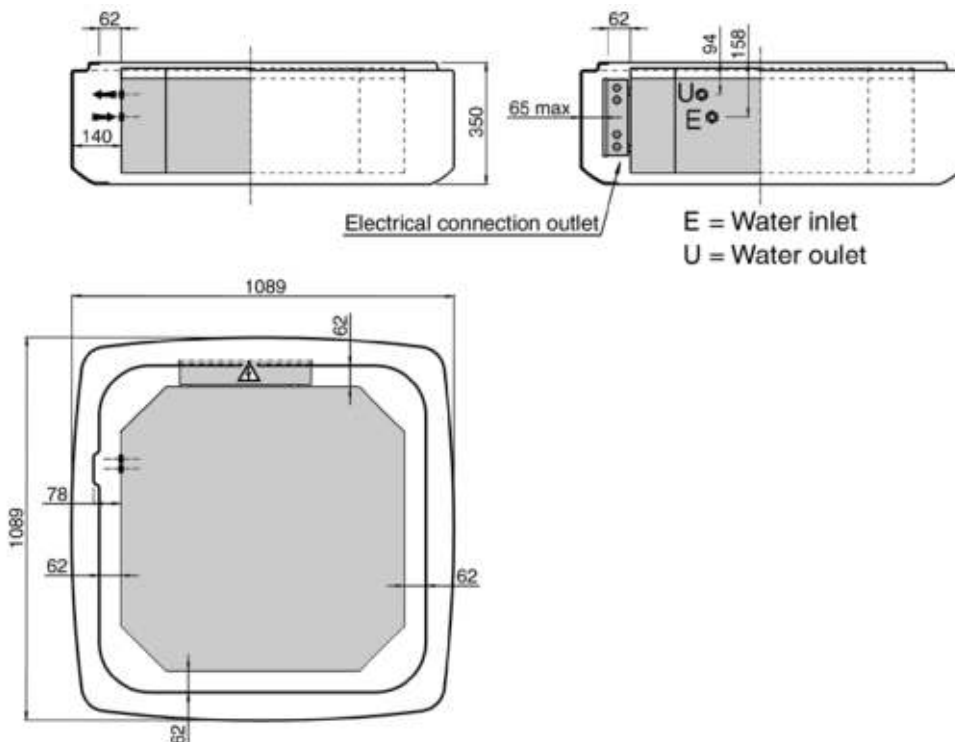

Warning: the electrical and water connections must enter the unit from above and must not interfere with the casing.

## Assembly diagram



**TL 0.2T-MCT / TL 1.2T-MCT  
TL 2.2T-MCT / TL 3.2T-MCT**



**TL 4.2T-MCT  
TL 5.2T-MCT / TL 6.2T-MCT**



## Components of the casing:

The casing includes:

- A – 4 corner covers
- B – 4 bottom brackets
- C – 4 top brackets
- D – Condensate collection tray
- E – Hardware (45 3.9x9.5mm TCX screws)
- F – Instruction sheet

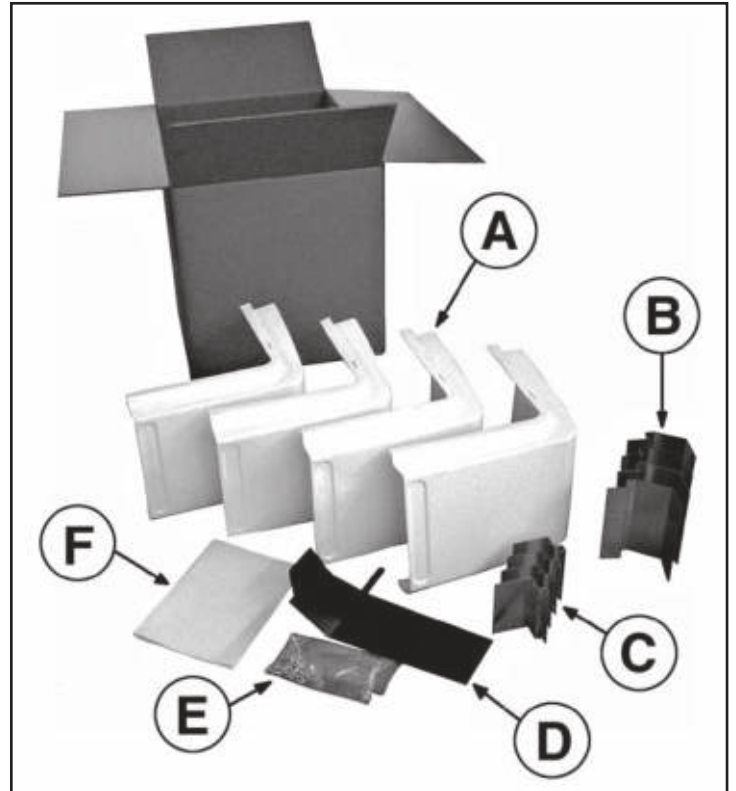

## Valve kit

The valve fittings allow the water pipes to be connected from above.

**TL 0.2-MCT / TL 1.2-MCT**  
**TL 2.2-MCT / TL 3.2-MCT**

Code 9079155

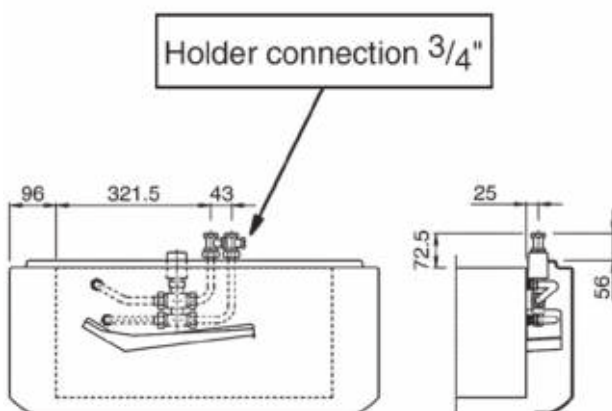

**TL 4.2-MCT**  
**TL 5.2-MCT / TL 6.2-MCT**

Code 9079156

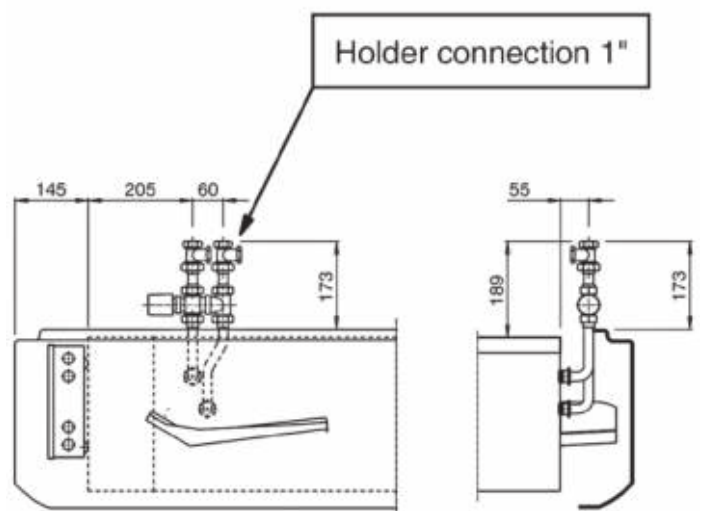

For the specifications of the valves, see page 15.

The descriptions and illustrations provided in this publication are not binding: the society reserves the right, whilst maintaining the essential characteristics of the types described and illustrated, to make, at any time, without the requirement to promptly update this piece of literature, any changes that it considers useful for the purpose of improvement or for any other manufacturing or commercial requirements.

