

Air displacement units

Air displacement units

SD-1

Application

Air displacement units are suitable for both industrial and comfort air conditioning applications. They are suitable for rooms characterised by high heat loads or heavy air pollution. Air displacement units supply air at large flow rates (up to 10.000 m³/h), at low air velocities (in the range from 0.1 to 0.3 m/s). Supplied air forms a so called »fresh air pool« in the occupied zone. Air is lifted in convection currents from heat sources to the ceiling layer, from which it is extracted from the room. In this way, even temperature field is maintained in the room, free of draught. Diffusers can be installed suspended from the ceiling, standing on the floor or hanging immediately above the occupied zone.

Description

Air displacement units are made of sheet steel and painted in RAL 9010. They can be coloured in any other RAL colour at to the customer's request. They consist of a mantle, a bottom plate and a top plate equipped with an inlet spigot. The standard shape of the spigot is round. At the customer's request, it can be rectangular according to the dimension of the unit.

The air displacement unit mantle perforation is designed according to the version. The versions without a filter (F1, F2 and F5) have mantle perforation with round openings (ϕ 5.5 x 8 mm, 37 % free area). The versions with a filter (F3, F4 and F6) have square openings (10 x 10 x 2 mm, 69 % free area).

To achieve a uniform distribution of air across the entire displacement surface, versions F3, F4 and F6 are recommended.

SD-1



SD-1: corner

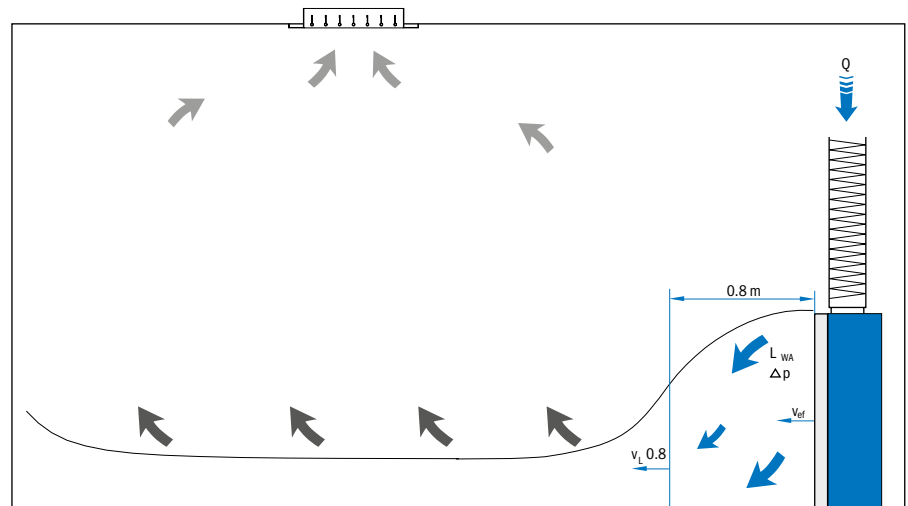

Definition of symbols

Q (m³/h)	Air flow rate	Δt_L (K)	Temperature difference between air jet and room temperature
v_L (m/s)	Supplied air velocity at the throw distance L=0.8 m	Δp_t (Pa)	Pressure drop
v_{eff}	Effective discharge air velocity	L_{WA} (dB(A))	Sound power level
Δt_z (K)	Temperature difference between supply and room air		

- 1. Perforated mantle
- 2. Bottom plate
- 3. Round inlet spigot
- 4. Control flap
- 5. Cone-shaped filter bag
- 5a. Dividing rings
- 6. Filter
- 7. Top plate

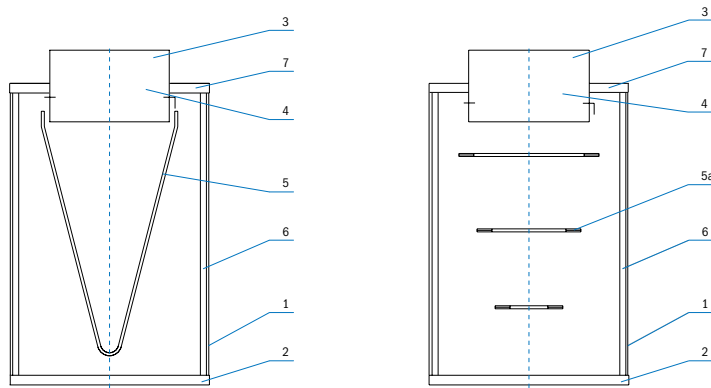

Versions

- F1:** without filters
- F2:** with the filter bag
- F3:** with the peripheral filter
- F4:** with the filter bag and the peripheral filter
- F5:** without filters and jet dividing rings
- F6:** with the peripheral filter and dividing rings

(R1) Air jet direction adjustment with blades (available with F1 and F5 version only).

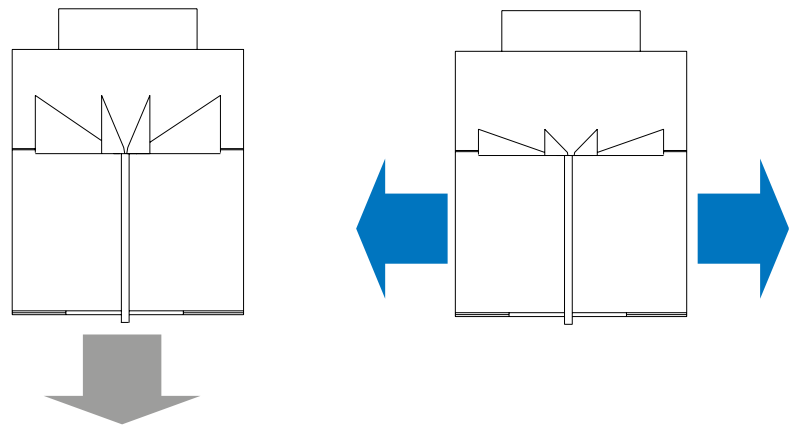

Special SD-3 version

An air displacement unit with regulation R1 and R2 must be mounted under the ceiling for correct operation. On the top plate, there is a special nut for mounting on the ceiling with a threaded rod.

(R2) Air jet direction adjustment with a flow control damper (available with F1 and F3 version only).

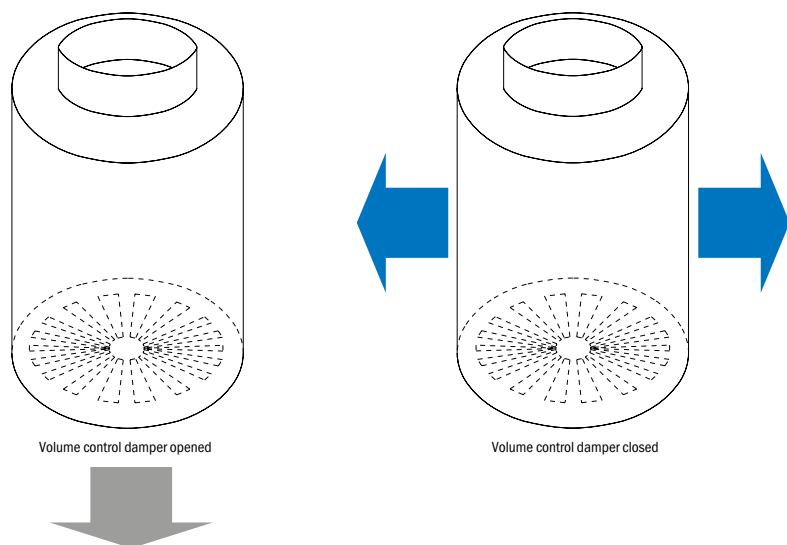

Dimensions

SD-1

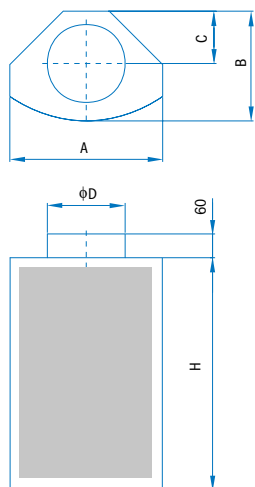

H
750
1000
1250
1500
2000
2500

Size	A	B	C	ϕD
400	283	180	100	123
600	424	275	135	148
800	566	300	150	178
1000	707	400	200	198
1500	1061	450	220	248
2000	1414	700	350	298

SD-2

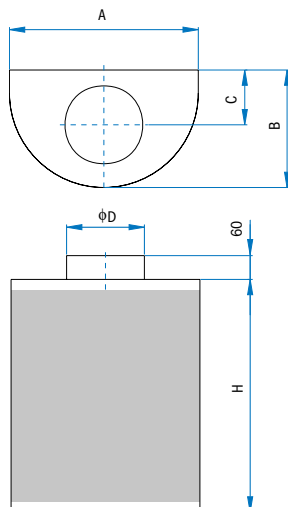

Size	A	B	C	ϕD
400	400	320	150	178
600	600	470	230	198
800	800	570	250	248
1000	1000	620	280	298
1500	1500	870	350	348
2000	2000	1120	430	398

SD-3

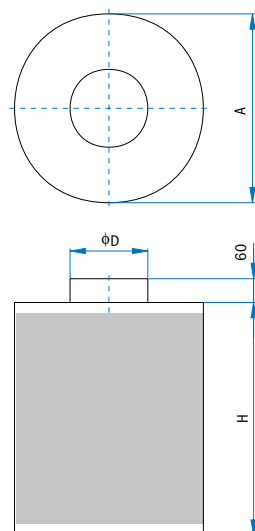

Size	A	ϕD
400	400	248
600	600	298
800	800	348
1000	1000	398
1500	1500	498
2000	2000	548

SD-6

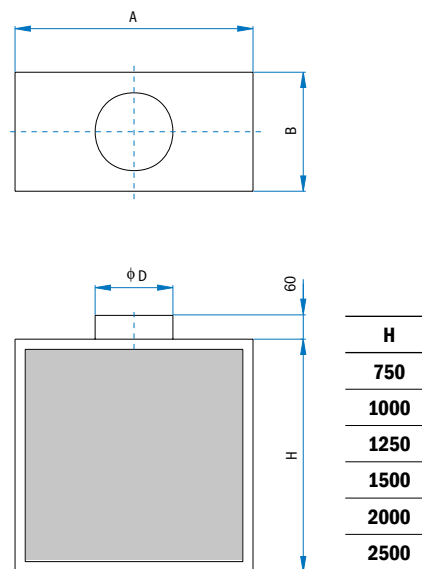

Size	A	B	ϕD
400	400	200	148
600	600	250	178
800	800	300	198
1000	1000	350	248
1500	1500	400	298
2000	2000	450	313

Inlet spigot $\phi d_{max} = 248$ mm

The minimum straight duct length $L = 3 \times \phi d$ before the diffuser is sufficient to stabilise the airflow at the diffuser inlet.

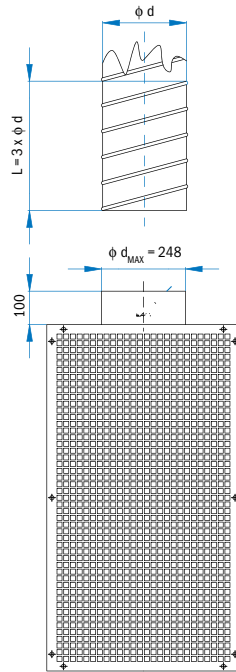

ϕd (mm)	Q_{max} (m ³ /h)
78	80
98	130
123	200
138	260
148	300
158	340
178	440
198	540
223	690
248	850

Example of correct assembly of airflow regulation SD-1, 2, 3, 6

Maximum airflow Q_{max} for the chosen inlet spigot with a size of ϕd has been calculated for the maximum recommended air velocity in the spigot of $V = 5$ m/s. Optimum air velocity in the spigot is 2 – 3 m/s.

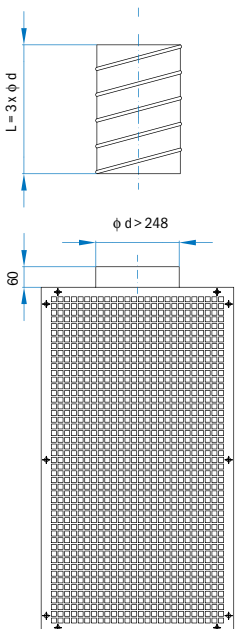

ϕd (mm)	Q_{max} (m ³ /h)
278	1080
298	1240
313	1370
353	1740
398	2220
448	2810
498	3480
558	4370
628	5540

Ordering key:

SD-3/F1/R1/ Size 400 H=750

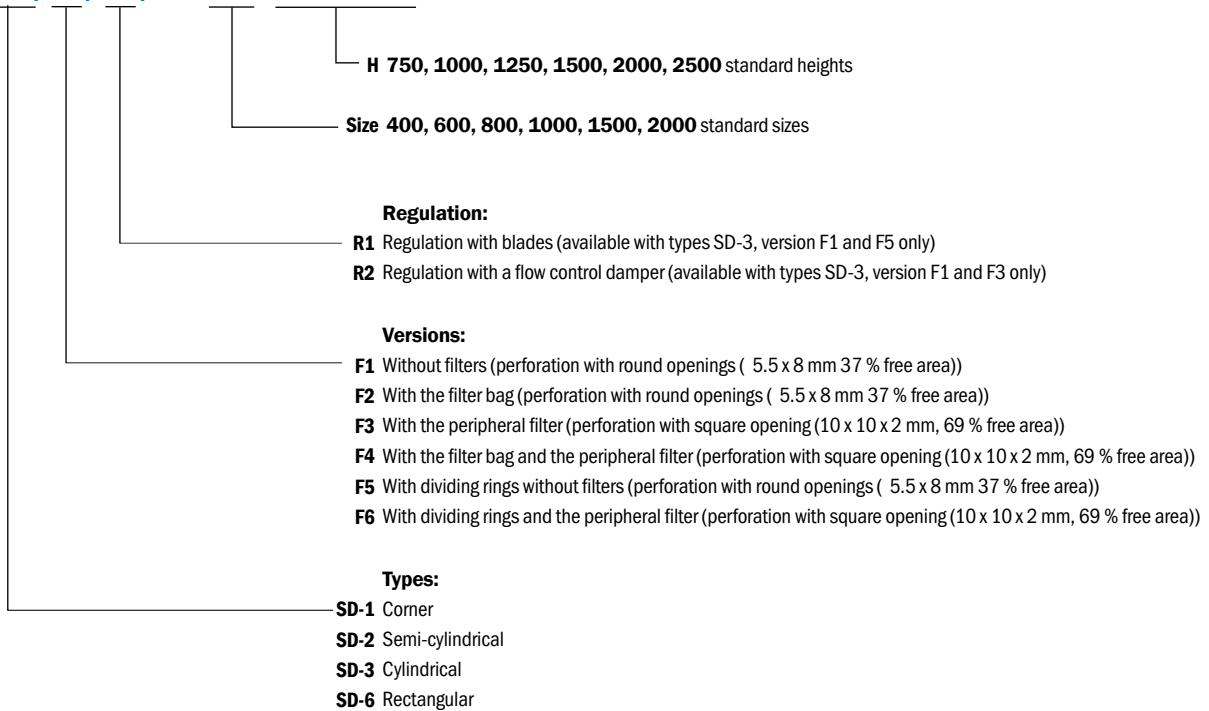

Technical data for SD-1

Diagrams to determine the supplied air velocity at the throw distance L=0.8 m:

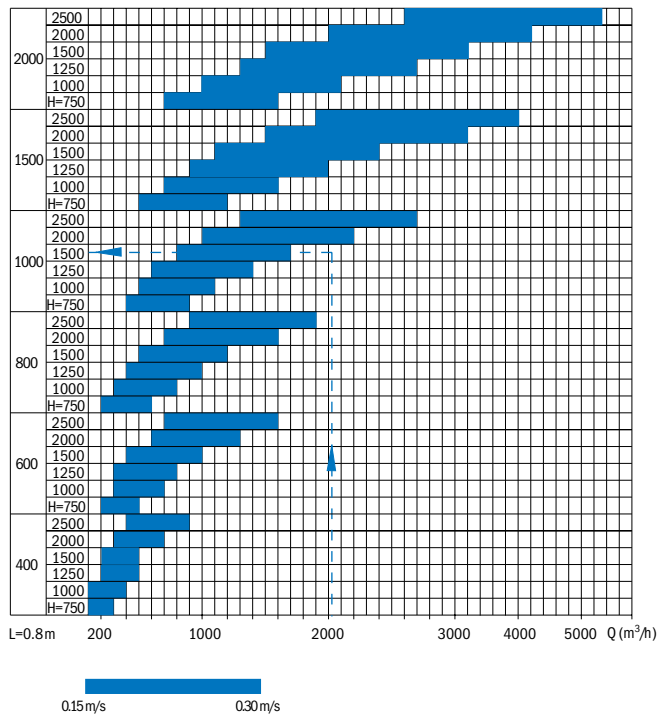

Pressure drop and noise level diagram:

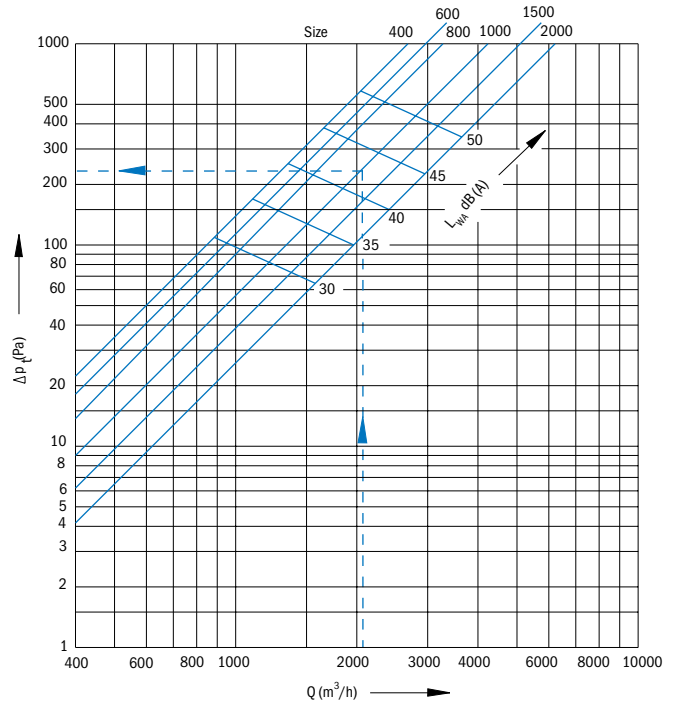

KF correction factor table

Correction	Size	750	1000	1250	1500	2000	2500
Δp _t for the type F3	400	1.44	1.00	0.80	0.26	0.16	0.11
	600	1.10	1.00	0.96	0.28	0.26	0.25
	800	1.06	1.00	0.97	0.29	0.27	0.27
	1000	1.10	1.00	0.96	0.33	0.31	0.30
	1500	1.04	1.00	0.98	0.34	0.33	0.33
Δp _t for the type F1	400	0.55	0.51	0.50	0.05	0.04	0.04
	600	0.56	0.51	0.49	0.14	0.13	0.13
	800	0.93	0.93	0.93	0.26	0.26	0.26
	1000	0.90	0.89	0.89	0.28	0.28	0.28
	1500	0.96	0.95	0.95	0.32	0.32	0.32
Δp _t for the type F4	400	2.33	1.42	1.11	0.47	0.28	0.19
	600	1.30	1.11	1.03	0.33	0.28	0.26
	800	1.19	1.07	1.02	0.32	0.29	0.28
	1000	1.29	1.11	1.02	0.38	0.33	0.31
	1500	1.13	1.05	1.01	0.36	0.34	0.34
2000	1.06	1.02	1.01	0.39	0.38	0.38	

Size	400	600	800	1000	1500	2000
L (m)	0.214	0.406	0.502	0.718	1.066	1.400

Definition of symbols

- Q (m³/h)** Air flow rate
- v_L (m/s)** Supplied air velocity at the throw distance L=0.8 m
- Δp_t (Pa)** Pressure drop
- L_{WA} (dB(A))** Sound power level

Example calculation

Q = 2000 m³/h
 We select size 1000; H = 1500
 $A_{ef} = 0.718 \times 1.5 \times 0.6944 = 0.748 \text{ (m}^2\text{)}$
 $v_{ef} = Q / (A_{ef} \times 3600) = 2000 / (0.748 \times 3600) = 0.74 \text{ m/s}$
 $L_{WA} = 42 \text{ dB(A)}$

Pressure drop:

- Tip F3**
 $\Delta p_t = \text{from the diagram} \times \text{KF (za H = 1500)} = 230 \times 0.33 = 75.9 \text{ Pa}$
- Tip F1**
 $\Delta p_t = \text{from the diagram} \times \text{KF (za H = 1500)} = 230 \times 0.28 = 64.4 \text{ Pa}$
- Tip F4**
 $\Delta p_t = \text{from the diagram} \times \text{KF (za H = 1500)} = 230 \times 0.38 = 87.4 \text{ Pa}$

Free area A_{ef}:

$A_{ef} = L \times H \times 0.6944 \text{ (m}^2\text{)}$ L-from the table
 $A_{ef} = L \times H \times 0.37 \text{ (m}^2\text{)}$ for the versions F1, F2 and F5 (without filter) and mantle perforation with round openings