

PV-2N

Description

- Fixed diffusion ring
- Adjustable disc for valve opening and closing
- Installation in built-in frame
- Peripheral foamy sealing strip
- Supply application

Material

- Made of sheet steel and coloured upon customer's request.

Component parts

1. Housing
2. Valve disc
3. Subframe

Installation

Frame is suitable for all installation types (wall, ceiling-or duct installation). It is fastened with screws. Place the valve in the groove and rotate it. Foamy sealant between the subframe and valve has a function to guarantee a perfect seal and to hold the valve in its position.

Air flow regulation

Adjust the air volume flow by rotating the valve disc in plus or minus direction.

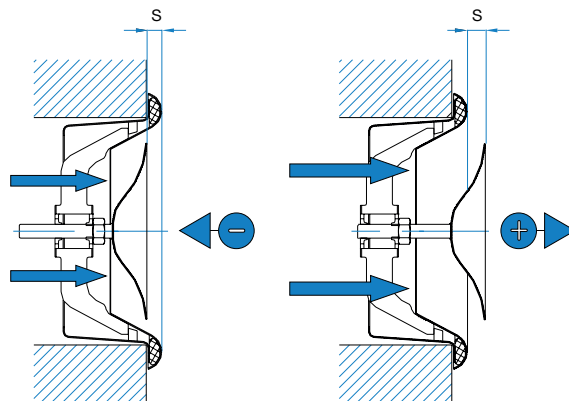
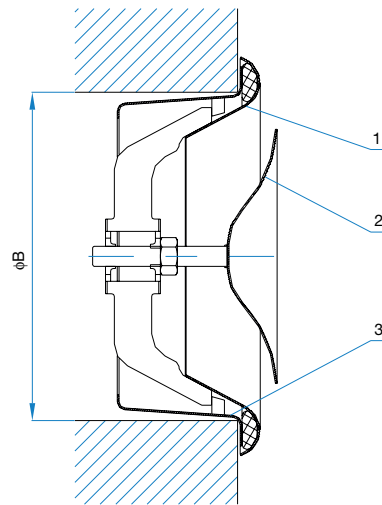
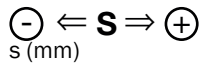

Dimensions:

Size	ΦB
100	100
125	125
150	150
160	160
200	200

Ordering example

Ventilating valve: **PV-2N**
 Size: **100**
 Pcs: **40**

PV-2N, size 100

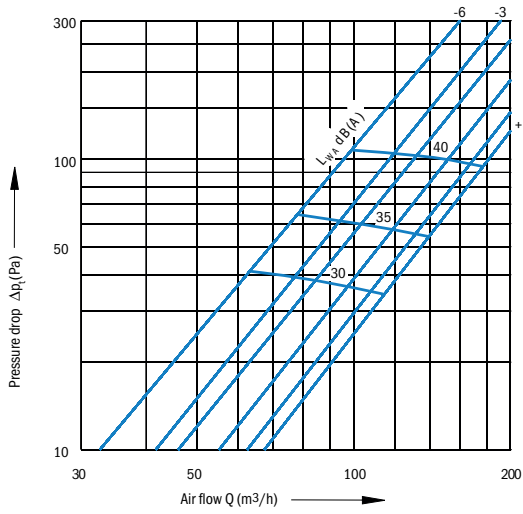

PV-2N, size 125

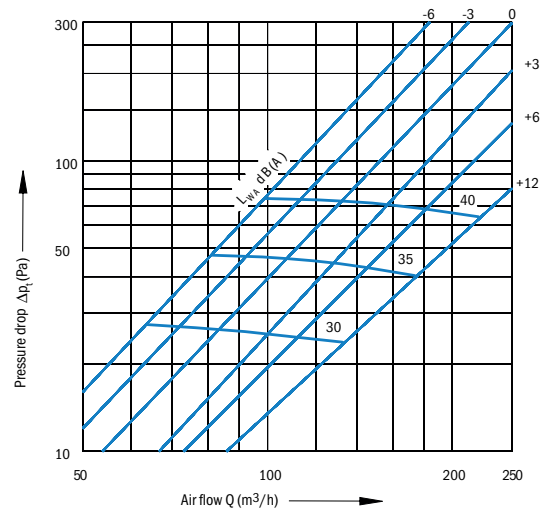

PV-2N, size 150

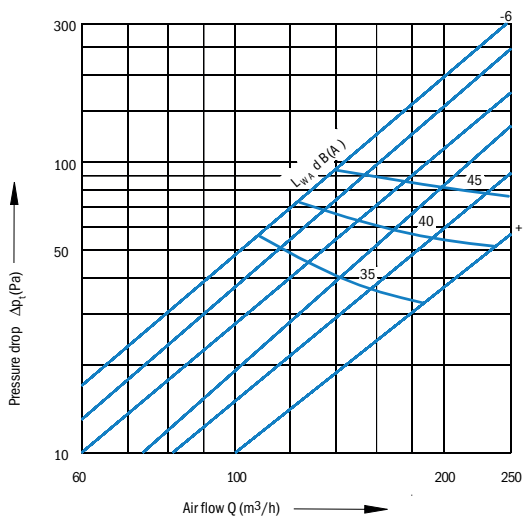

PV-2N, size 160

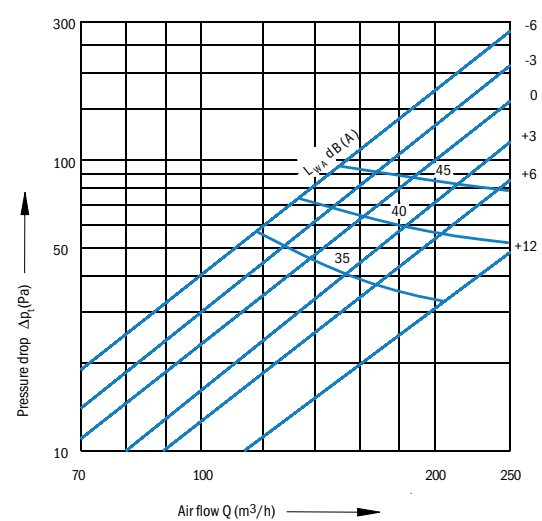

PV-2N, size 200

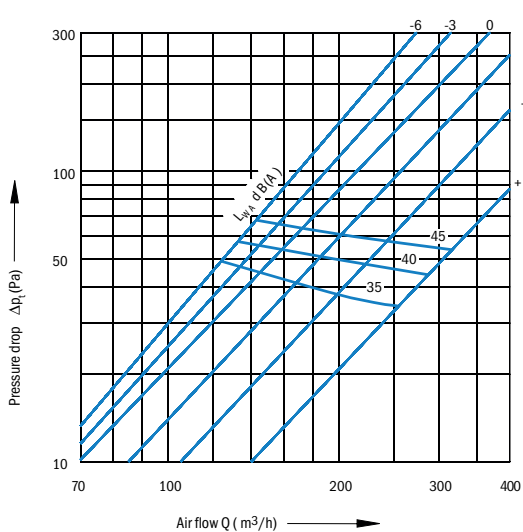

Definition of symbols

- Q (m³/h)** Air flow
- Δp_t (Pa)** Pressure drop
- L_{WA} (dB(A))** Sound power level

VENTILATING GRILLES,
VENTILATING VALVES

CIRCULAR DIFFUSERS,
SQUARE DIFFUSERS

SWIRL DIFFUSERS,
VARIABLE SWIRL
DIFFUSERS

SLOT DIFFUSERS,
ROUND DUCT DIFFUSERS

AIR DISPLACEMENT
UNITS

SUPPLY AIR NOZZLES

EXTERNAL ELEMENTS

AIR FLOW
CONTROL UNITS

SOUND ATTENUATORS,
SOUND ATTENUATING
LOUVRES