

# Fire damper

# FBC1-4-7



## Description

Lindab's new cartridge circular fire damper guaranteeing perfect insulation from heat and complete sealing and both for hot and cold fumes and gases.

The fire dampers FBC1, FBC4, FBC7, series, are suitable for the insertion in circular ducts up to 200mm in diameter, allow maximum safety in preventing the spread of fire inside the buildings, guaranteeing perfect insulation from heat and complete sealing both for hot and cold fumes and gases as demonstrated by the numerous tests carried out according to the EN 1366-2 standard.

Tested and classified in accordance with EN 1366-2 and EN 13501-3 regulations with 300 Pa depression.

Product code		
Type	FBC	Circular cartridge fire damper
Model	1	EI 60 S without terminal valve
	2	EI 60 S with terminal valve
	4	EI 90 S without terminal valve
	5	EI 90 S with terminal valve
	7	EI 120 S without terminal valve
	8	EI 120 S with terminal valve
Position indication microswitches	S0	Without position microswitch
	S1	With position indication microswitch
Dimension	XYZ	Nominal diameter (mm)

## Ordering example

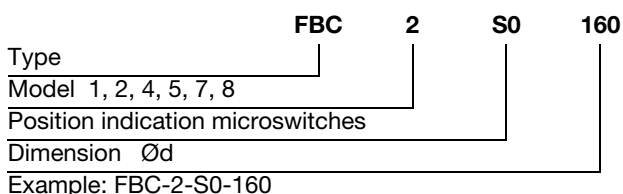

## Dimensions

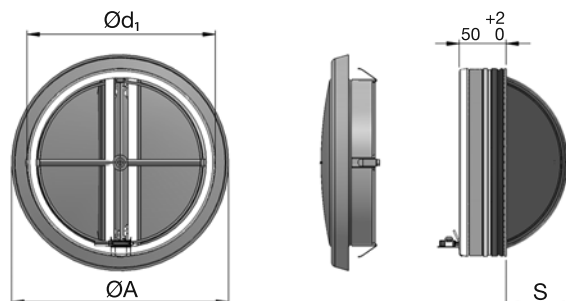

Ød <sub>1</sub> nom	S mm	ØA mm	m kg
100	21	149	0,2
125	34	169	0,3
160	51	195	0,4
200	72	240	0,6

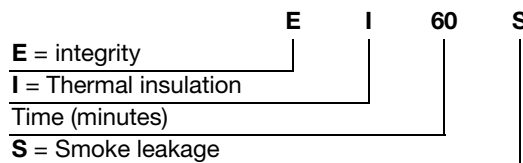

The fire resistance classifications refer to the conditions obtained by rigorously applying the instructions indicated in the Technical Manual, with reference both to the construction of the wall/ceiling and the installation of the damper